

ISSUE EMD-ES1674



# **Robin Engines**

Air-cooled, 4-cycle Gasoline Engine

Model

**EH63**

**EH64**

**EH65**

# **SERVICE MANUAL**



# CONTENTS

<i>Section</i>	<i>Title</i>	<i>Page</i>
<b>1.</b>	<b>SPECIFICATIONS .....</b>	<b>1</b>
<b>2.</b>	<b>PERFORMANCE .....</b>	<b>2</b>
2-1	MAXIMUM OUTPUT .....	2
2-2	CONTINUOUS RATED OUTPUT .....	2
2-3	MAXIMUM TORQUE .....	2
2-4	PERFORMANCE CURVES .....	3
<b>3.</b>	<b>FEATURES .....</b>	<b>6</b>
<b>4.</b>	<b>GENERAL DESCRIPTION OF ENGINE COMPONENTS .....</b>	<b>7</b>
4-1	CYLINDER AND CRANKCASE .....	7
4-2	MAIN BEARING COVER .....	7
4-3	CRANKSHAFT .....	7
4-4	CONNECTING ROD AND PISTON .....	8
4-5	PISTON RINGS .....	8
4-6	CAMSHAFT .....	8
4-7	CYLINDER HEAD .....	9
4-8	VALVE ARRANGEMENT .....	9
4-9	GOVERNOR SYSTEM .....	9
4-10	COOLING SYSTEM .....	10
4-11	LUBRICATION SYSTEM.....	10
4-12	IGNITION SYSTEM .....	10
4-13	CHARGING SYSTEM .....	10
4-14	CARBURETOR .....	11
4-15	AIR CLEANER .....	11
4-16	FUEL PUMP .....	11
4-17	SECTIONAL VIEW OF ENGINE .....	12
<b>5.</b>	<b>DISASSEMBLY AND REASSEMBLY .....</b>	<b>14</b>
5-1	PREPARATIONS AND SUGGESTIONS .....	14
5-2	SPECIAL TOOLS .....	14
5-3	DISASSEMBLY PROCEDURES .....	15
5-4	REASSEMBLY PROCEDURES .....	30
5-5	BREAK-IN OPERATION .....	43
<b>6.</b>	<b>MAGNETO .....</b>	<b>44</b>
6-1	OPERATION AND FUNCTION .....	44

<i>Section</i>	<i>Title</i>	<i>Page</i>
<b>7.</b>	<b>LUBRICATION SYSTEM .....</b>	<b>46</b>
	7-1 OPERATION AND FUNCTION .....	46
<b>8.</b>	<b>CARBURETOR .....</b>	<b>47</b>
	8-1 OPERATION AND FUNCTION .....	47
	8-2 COMPORNENT PARTS .....	49
<b>9.</b>	<b>ELECTRIC STARTER .....</b>	<b>50</b>
	9-1 OPERATION AND FUNCTION .....	50
	9-2 COMPORNENT PARTS .....	51
<b>10.</b>	<b>TROUBLESHOOTING .....</b>	<b>52</b>
	10-1. NO ENGINE OPERATION .....	52
	10-2. STARTING DIFFICULTIES .....	53
	10-3. INSUFFICIENT OUTPUT .....	54
	10-4. OVERHEAT .....	54
	10-5. ROUGH IDLING .....	55
	10-6. HIGH ENGINE OIL CONSUMPTION .....	55
	10-7. HIGH FUEL CONSUMPTION .....	56
	10-8. DETONATION .....	56
	10-9. ENGINE MISFIRE .....	57
<b>11.</b>	<b>INSTALLATION .....</b>	<b>58</b>
	11-1 INSTALLING .....	58
	11-2 VENTILATION .....	58
	11-3 EXHAUST GAS DISCHARGE .....	58
	11-4 POWER TRANSMISSION TO DRIVEN MACHINES .....	58
<b>12.</b>	<b>SERVICE DATA .....</b>	<b>59</b>
	12-1 CLEARANCE DATA AND LIMITS .....	59
	12-2 TORQUE SPECIFICATIONS .....	65
	12-3 OIL GRADE CHART .....	66
<b>13.</b>	<b>MAINTENANCE AND STORAGE .....</b>	<b>67</b>
	13-1 DAILY MAINTENANCE .....	67
	13-2 PERIODIC MAINTENANCE SCHEDULE .....	67
	13-3 ENGINE STORAGE .....	69

# 1. SPECIFICATIONS

MODEL	EH63D	EH64D	EH65D
Type	Air-Cooled, 4-Stroke, V-Twin Cylinder, Horizontal P.T.O. shaft, OHV Gasoline Engine		
Bore x stroke	2 - 80 mm x 65 mm (3.15 in x 2.56 in)		
Displacement	653 cm <sup>3</sup> . (39.9 cu. in)		
Compression Ratio	8.3		
Continuos output kW (HP) / rpm	10.8 (14.5) / 3,600	11.9 (16.0) / 3,600	12.7 (17.0) / 3,600
Maximum output kW (HP) / rpm	13.4 (18.0) / 3,600	15.3 (20.5) / 3,600	16.4 (22.0) / 3,600
Max. Torque N-m (kgf-m) / rpm	43.3 (4.41) / 2,000	44.3 (4.52) / 2,200	45.6 (4.65) / 2,500
Direction of Rotation	Counterclockwise as viewed from P.T.O. shaft side		
Cooling System	Forced Air Cooling		
Valve Arrangements	Overhead Valve (OHV)		
Lubrication	Full presure type with Trochoid Pump		
Lubricant	Automobile Engine Oil SAE #20, #30 or 10W-30 ; Class SE or higher		
Capacity of Lubricant	1.55 L (52.48 oz.)		
Carburetor	Horizontal Shaft, Float Type		
Fuel	Automobile Unleaded Gasoline		
Fuel Feed System	Diaphragm Pump (Pulse type)		
Ignition System	Flywheel Magneto (Solid State)		
Spark Plug	NGK- BP6ES (Champion - N9YC)		
Charging Capacity	12 V - 15 A		
Starting System	Electric Starter		
Governor System	Centrifugal Flyweight Type		
Air Cleaner	Double Element Type		
Dry Weight	44 kg (97.0 lb.)		
Dimension (L x W x H)	317 mm x 477 mm x 475 mm (12.5 in x 18.8 in x 18.7 in)		

Specifications are subject to change without notice.

## **2. PERFORMANCE**

### **2-1 MAXIMUM OUTPUT**

The maximum output is the output of an engine with its throttle valve fully opened under the condition that all the moving parts are properly worn in after the initial break-in period.

A new engine may not produce full maximum output while its moving parts are still not broken-in.

NOTE :

Power curves shown in the following charts are made in conformity to SAE internal combustion engine standard test code J1349

### **2-2 CONTINUOUS RATED OUTPUT**

The continuous rated output is the output of an engine at optimum governed speed which is most favorable from the view point of engine's life and fuel consumption.

When the engine is installed on a certain equipment, it is recommended that the continuous output required from the engine be kept below this continuous rated output.

### **2-3 MAXIMUM TORQUE**

The maximum torque is the torque at the output shaft when the engine is producing maximum output at certain revolution.

## 2-4 PERFORMANCE CURVES

EH63D

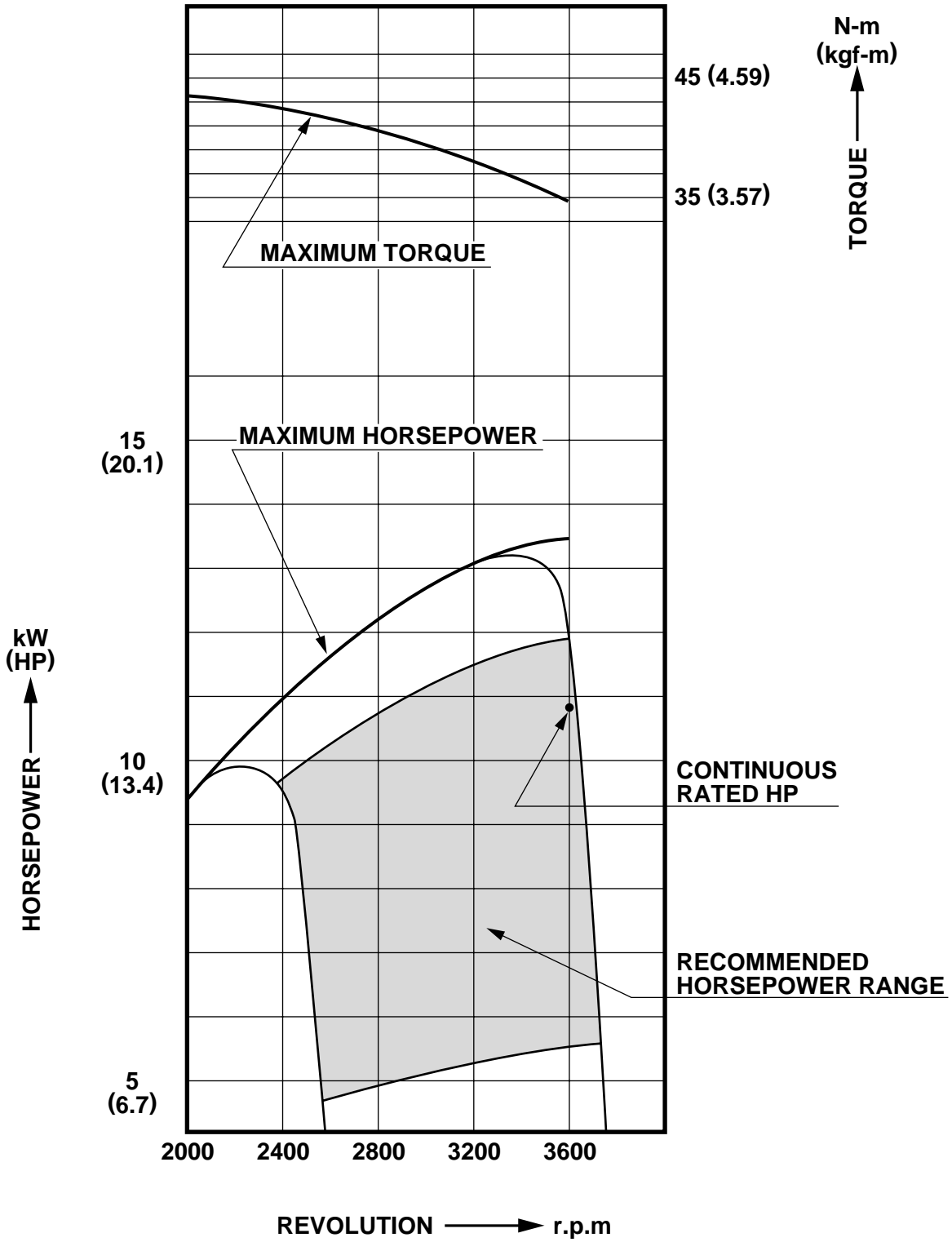

**EH64D**

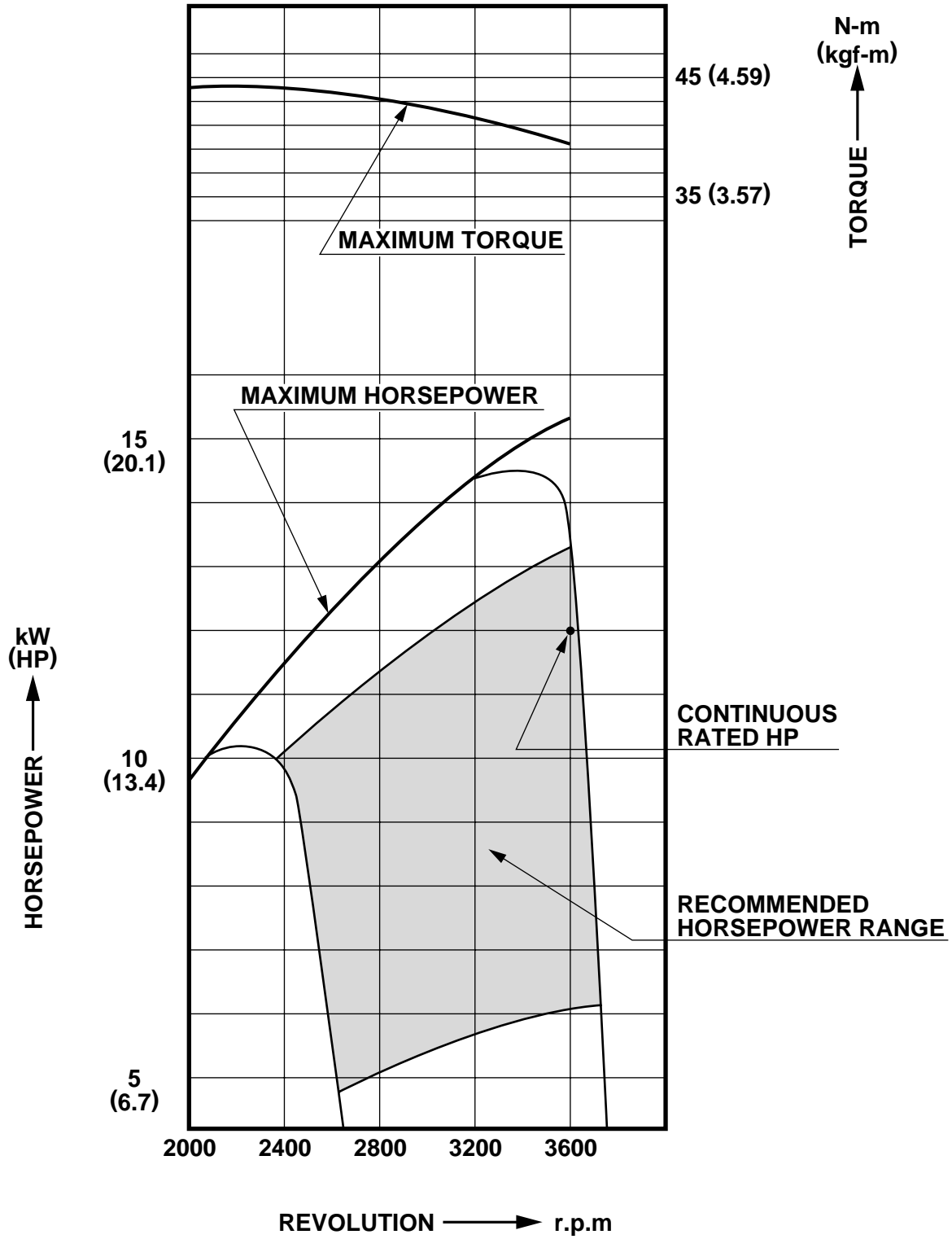

**EH65D**

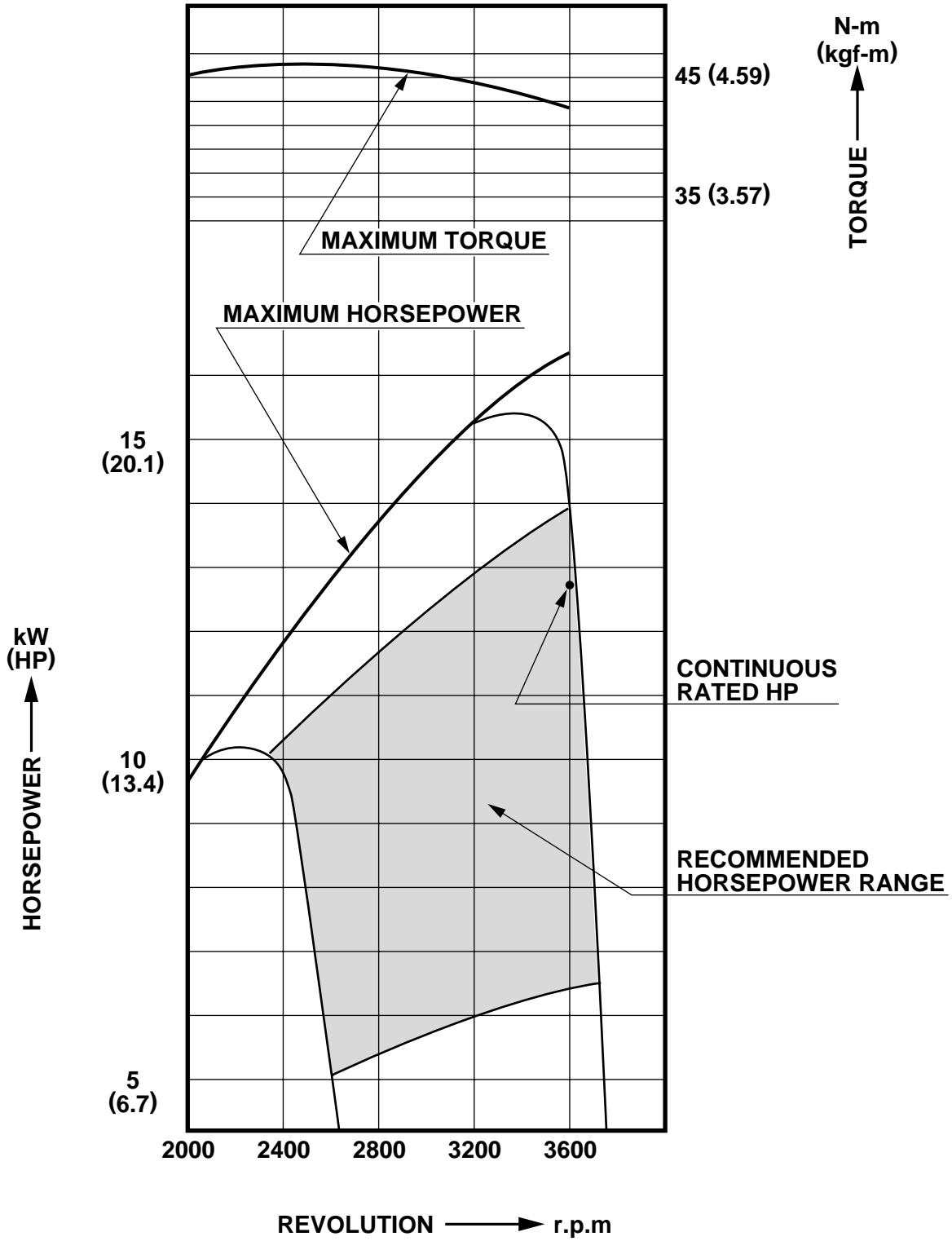



### 3. FEATURES

The overhead valve arrangement is adopted for ensuring high power, low fuel consumption and low oil consumption.

The adoption of twin-cylinder in the angle of 90 degree (V arrangement) and crankcase in one piece, plastic blower housing etc. offers a compactness and light weight, making the arrangements for installing the engine much easier into many kinds of power equipments.

The forged steel crankshaft and high loading capacity ball bearing offer high durability, and full pressure lubrication system with trochoid type oil pump and large capacity air cleaner with dual elements enhance the reliability.

The effective combustion chamber shape and the precisely tuned intake and exhaust valve system enhance the low exhaust emission and ensure the engine characteristics of high torque at low speed.

The carburetor with fuel cut valve, 12V-15A alternator and pulse type fuel pump are employed as standard features so that the engine can be utilized for many usage.

## 4. GENERAL DESCRIPTION OF ENGINE COMPONENTS

ROBIN EH63D/ 64D/ 65D series engine is air-cooled, 4-stroke, twin-cylinder, OHV arrangement gasoline engine. The twin-cylinder is located in the angle of 90 degree; #1 cylinder is in the RH side and #2 cylinder in LH side as viewed from flywheel (cooling fan) side.

### 4-1 CYLINDER AND CRANKCASE

The twin-cylinder and crankcase is single piece aluminum die-casting.

The cylinder liner, made of special cast iron, is molded into the aluminum casting.

The crankcase has a mounting surface on the output shaft side, where the main bearing cover is attached.

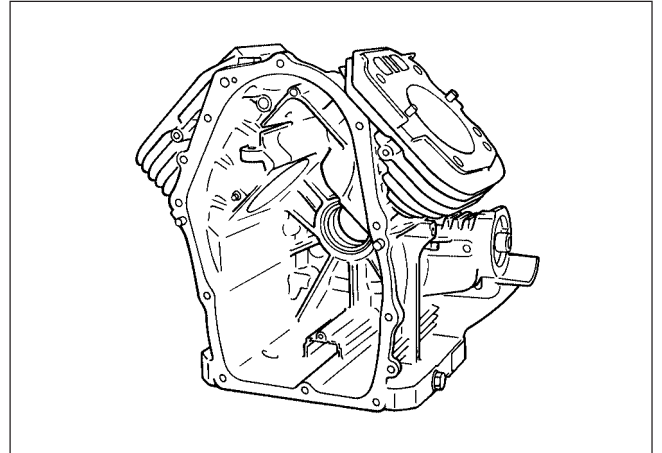

*Fig. 4-1*

### 4-2 MAIN BEARING COVER

The main bearing cover is an aluminum die-casting, which is mounted on the output shaft side of the crankcase.

Pilots and bosses are machined on the cover for direct mounting of the engine onto such machines as generators and pumps.

It is easy to inspect inside of the engine, after removing the main bearing cover.

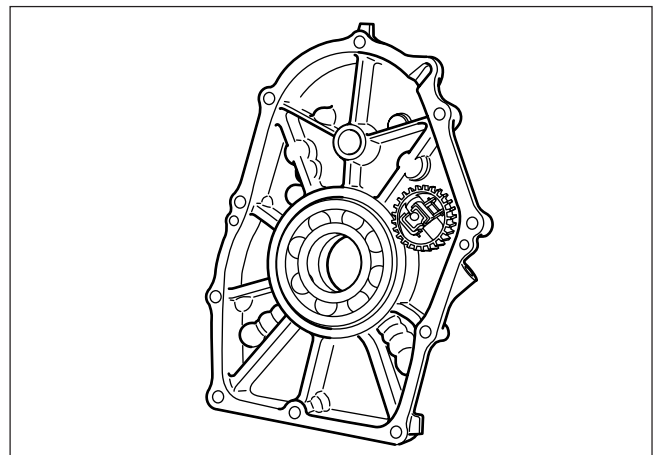

*Fig. 4-2*

### 4-3 CRANKSHAFT

The crankshaft is forged carbon steel, and the crank pin is induction-hardened.

The output end of the shaft has a crankshaft gear pressed into position.

Engine oil passages are provided onto the journal and pin portions of crankshaft for lubrication.

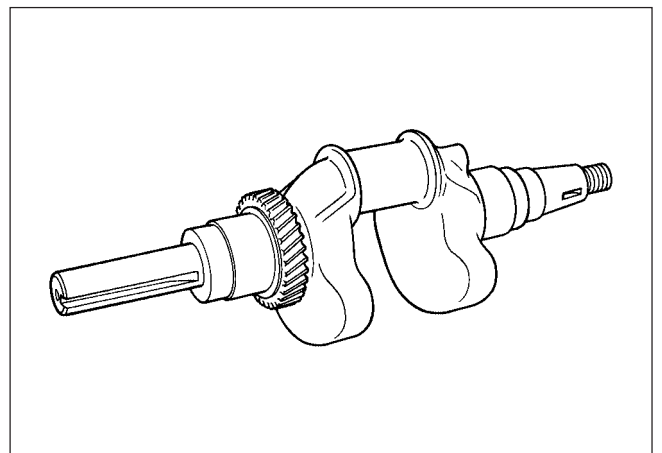

*Fig. 4-3*

#### 4-4 CONNECTING ROD AND PISTON

The connecting rod is forged aluminum alloy, and its large and small ends function as bearings.

The piston is an aluminum alloy casting, and carries two compression rings and one oil ring.

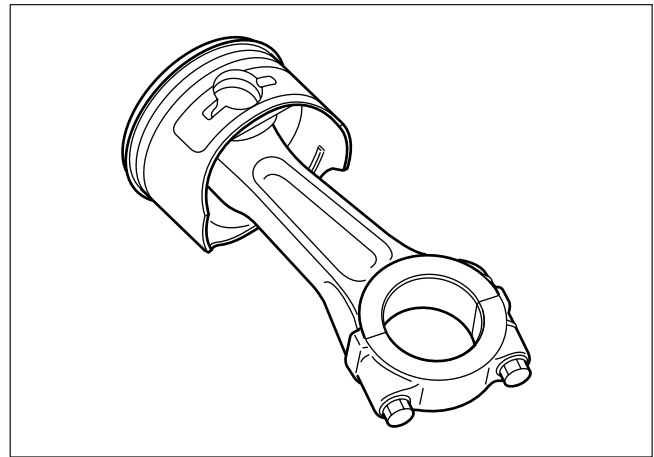

Fig. 4-4

#### 4-5 PISTON RINGS

The piston rings are made of special cast iron.

The profile of the top ring is barrel face and the second ring has a tapered face.

The oil ring is designed for better sealing and less oil consumption, in combination with 3 pieces.

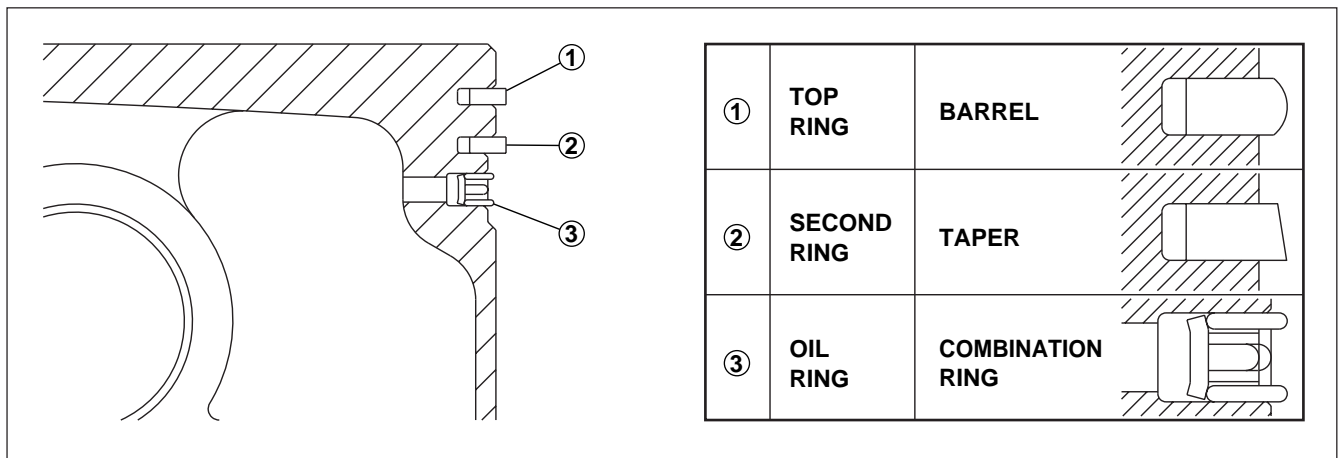

Fig. 4-5

#### 4-6 CAMSHAFT

The camshaft is made of special cast iron and camshaft gears are casted together in one piece.

Each 2 cam robs are provided for intake and exhaust valves correspondingly.

Both sides of the shaft fit into the plane bearings on the crankcase and main bearing cover.

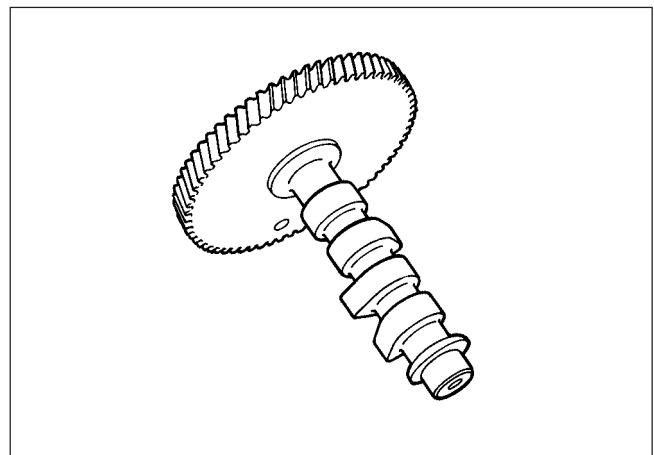

Fig. 4-6

## 4-7 CYLINDER HEAD

The cylinder head is an aluminum die-casting which utilizes semi-spherical type combustion chamber for the high combustion efficiency.

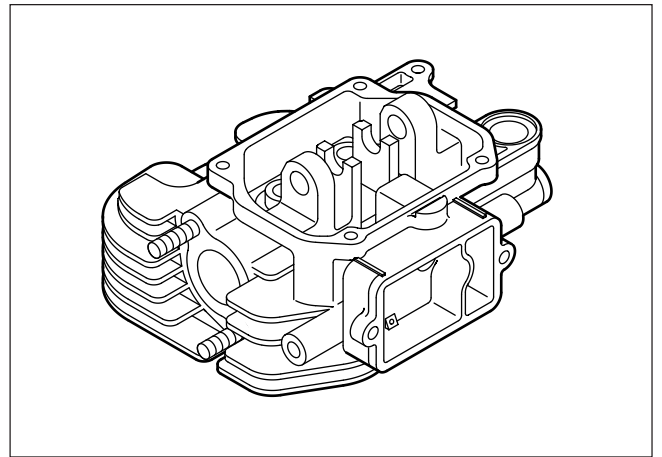

Fig. 4-7

## 4-8 VALVE ARRANGEMENT

The intake valve is located on flywheel side of the cylinder head.

The cooling fins and passages design lead cooling air to the exhaust valve area for the optimum cooling.

Hard alloy valve seats are molded in the cylinder head and stellite is fused to the exhaust valve face.

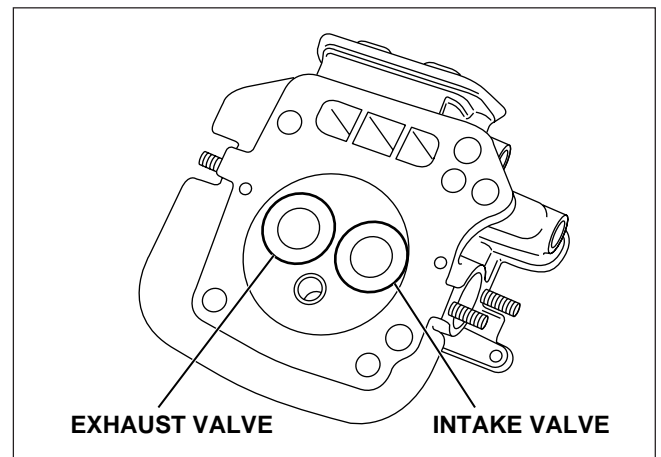

Fig. 4-8

## 4-9 GOVERNOR SYSTEM

The governor is a centrifugal flyweight type which ensures constant operation at the selected speed against load variations.

The governor gear with governor weights is installed inside of main bearing cover and driven by the crankshaft.

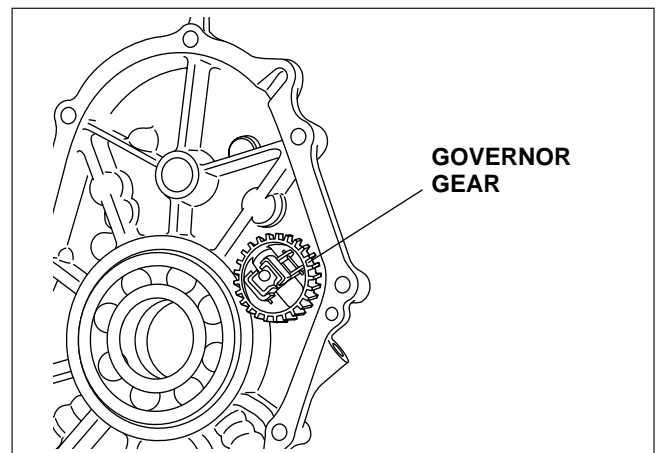

Fig. 4-9

## 4-10 COOLING SYSTEM

The large fins on the flywheel provide sufficient cooling air capacity for cylinder and cylinder head.

The cylinder baffle helps the cooling air flow efficiently.

## 4-11 LUBRICATION SYSTEM

The engine is furnished with full pressure lubrication system.

The trochoid type oil pump is driven by crankshaft and delivers pressurized engine oil through the full-flow type oil filter to the journal and pin portions of crankshaft and camshaft.

## 4-12 IGNITION SYSTEM

The ignition system is a transistor controlled magneto ignition system which consists of a flywheel and an ignition coil with a built-in transistor installed onto the crankcase.

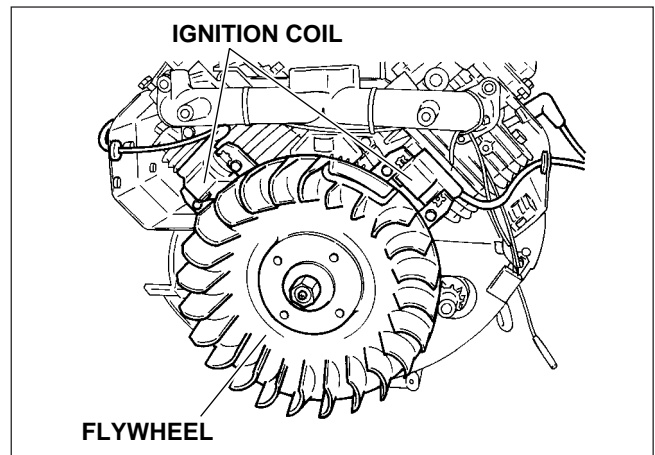

*Fig. 4-10*

## 4-13 CHARGING SYSTEM

Multipolar charging coil is provided inside of flywheel. Charging capacity is 12V-15A.

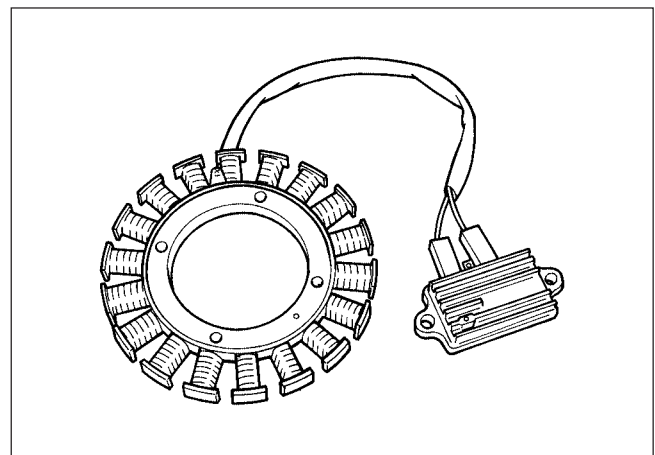

*Fig. 4-11*

#### 4-14 CARBURETOR

The engines are equipped with a down draft carburetor that has a float controlled fuel system and a fixed main jet.

The carburetors are calibrated carefully for the sure starting, good acceleration, low fuel consumption and sufficient output.

Fuel cut solenoid valve is provided to prevent engine running on when the key switch is turned to off.

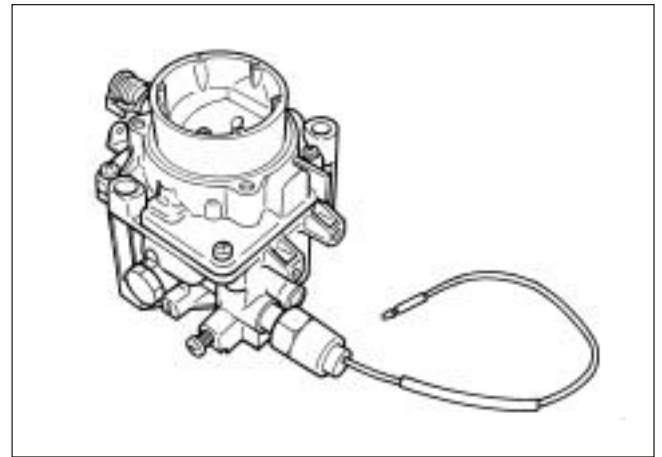

Fig. 4-12

#### 4-15 AIR CLEANER

The air-cleaner is a heavy-duty type with a dual element system; primary side is urethane form (half-wet) and secondary side is dry type.

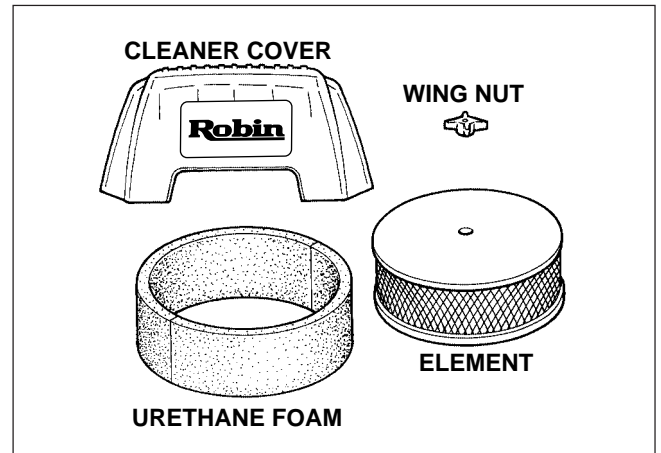

Fig. 4-13

#### 4-16 FUEL PUMP

The engines are equipped with a diaphragm type fuel pump which is operated by the crankcase inside vacuum pressure.

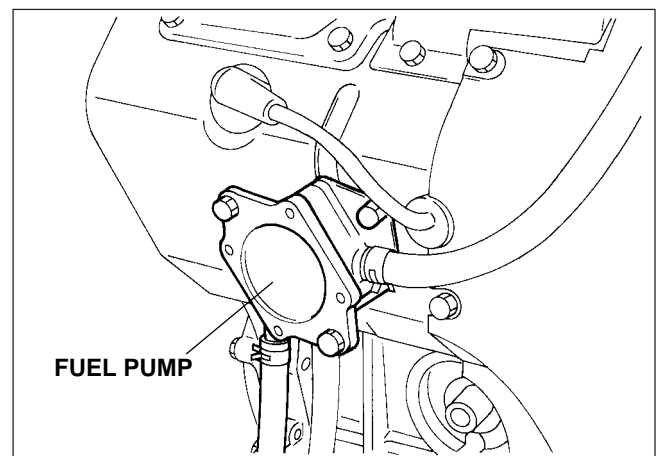

Fig. 4-14

4-17 SECTIONAL VIEW OF ENGINE

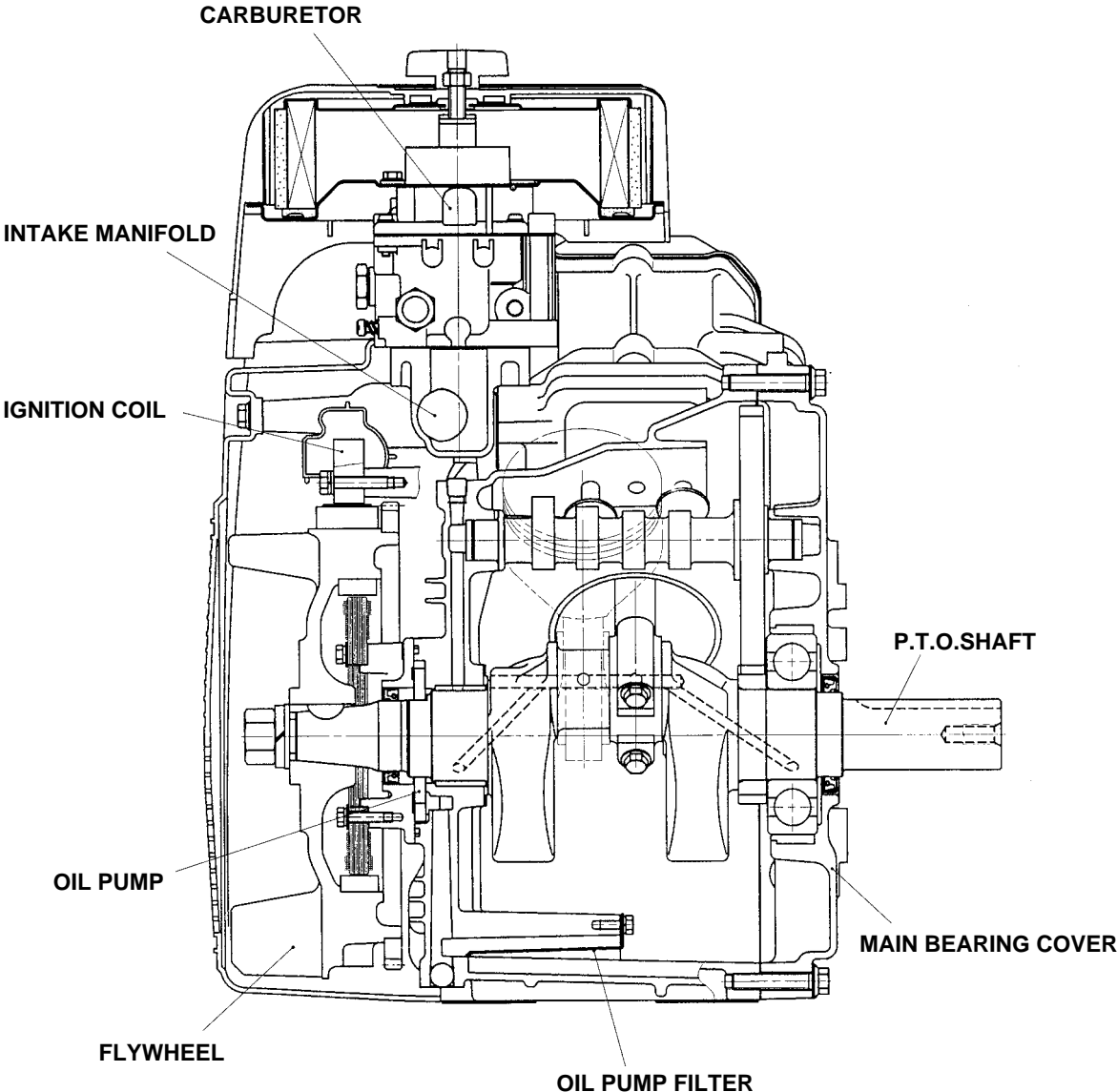

Fig. 4-15

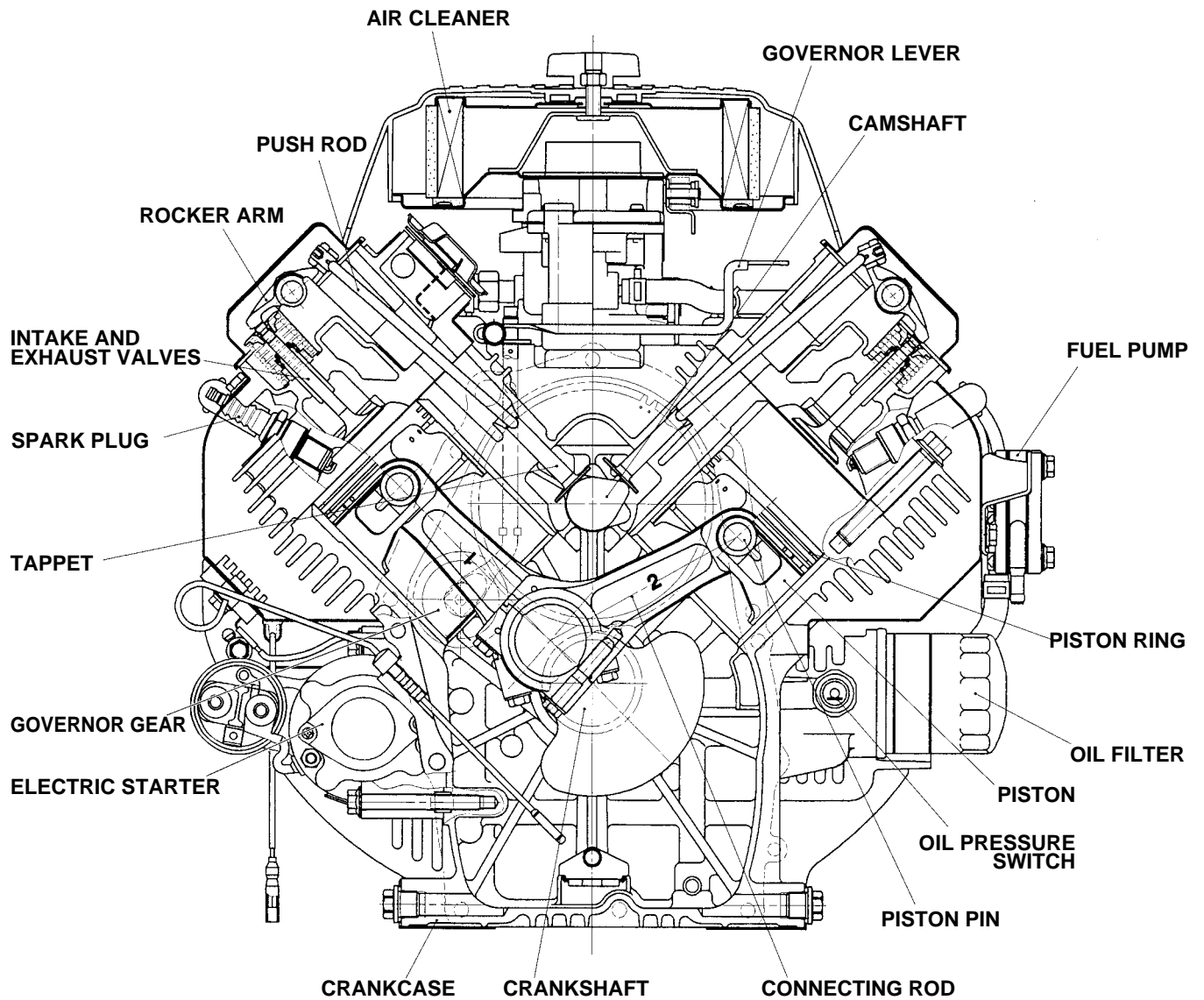

Fig. 4-16



## 5. DISASSEMBLY AND REASSEMBLY

### 5-1 PREPARATIONS AND SUGGESTIONS

When disassembling the engine, memorize the locations of individual parts so that they can be reassembled correctly. If you are uncertain of identifying some parts, it is suggested that tags be attached to them.

Have boxes ready to keep disassembled parts by group.

To prevent losing and misplacing, temporarily assemble each group of disassembled parts.

Carefully handle disassembled parts, and clean them with washing oil if necessary.

Use the correct tools in the correct way.

### 5-2 SPECIAL TOOLS

Tool No.	Tool	Use
228-95001-17	Flywheel puller with bolt	For pulling off the flywheel EH63,64,65,72 / DY30,35,41,42

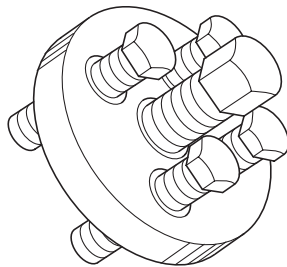

**FLYWHEEL PULLER**

*Fig. 5-1*

### 5-3 DISASSEMBLY PROCEDURES

Step	Parts to remove	Remarks and procedures	Fasteners
1	Engine oil drain	Drain engine oil by removing plugs located on both side of crankcase.	
2	Muffler cover Muffler	Be careful not to lose muffler gasket.	M6 × 8 ; 6 pcs. Flange bolt M8 ; 4 pcs. SUS. Flange nut
3	Muffler bracket		M6 × 16 ; 2 pcs.

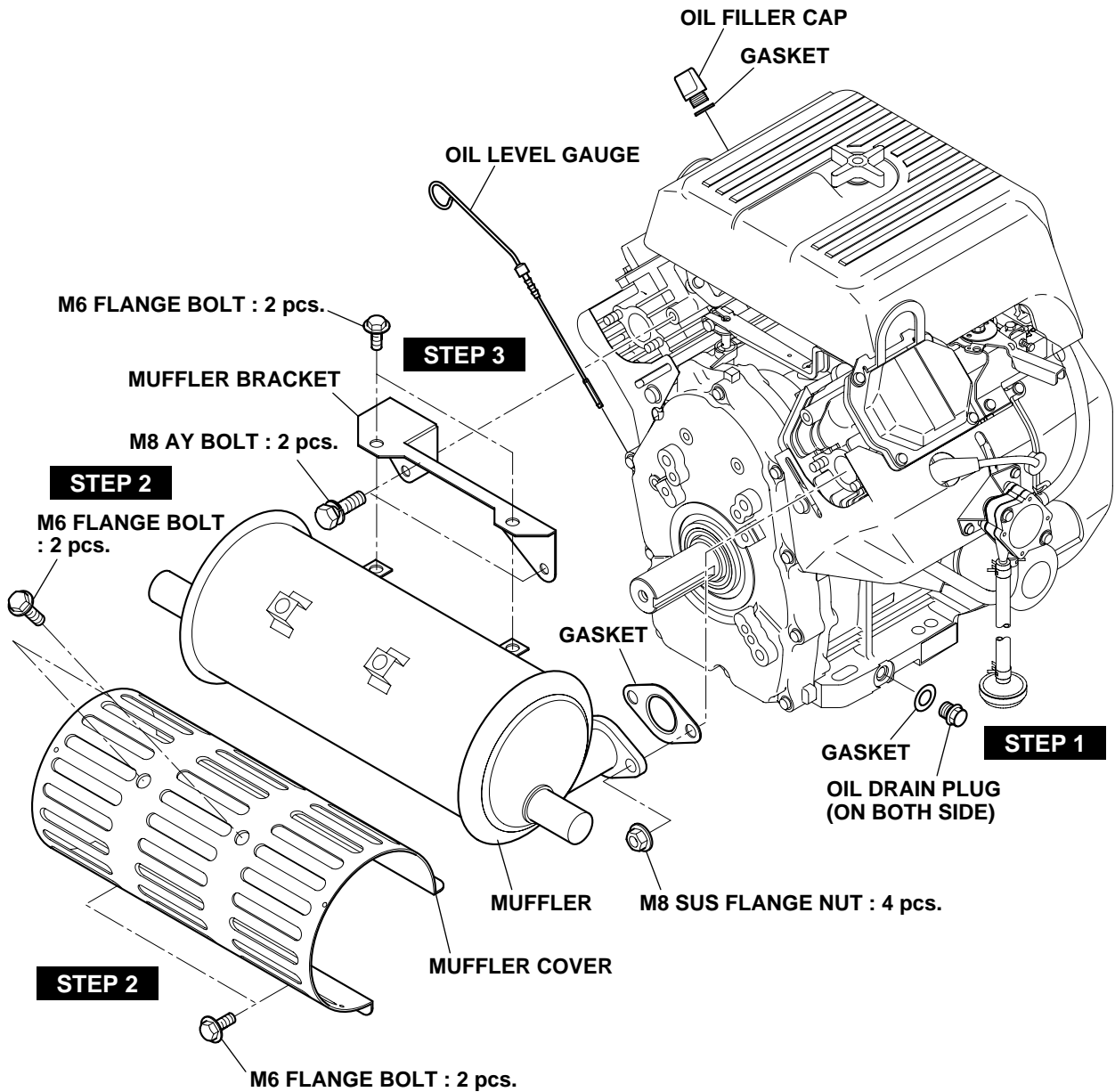

Fig. 5-2

Step	Parts to remove	Remarks and procedures	Fasteners
4	Air cleaner cover and elements	Remove breather pipe from #1 cylinder head.	10-32 x 11mm ; 3 pcs.
5	Air cleaner base		

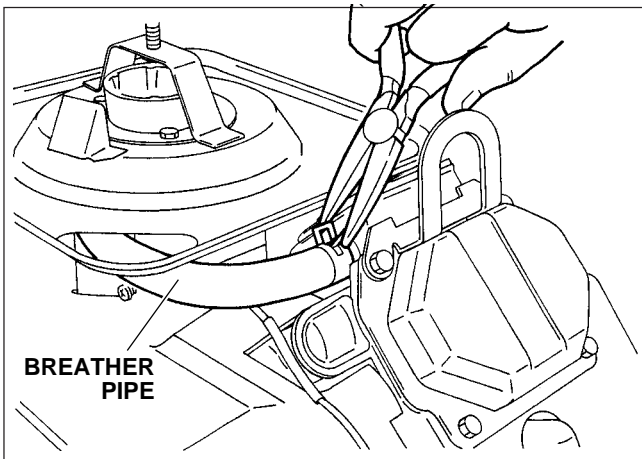

Fig. 5-4

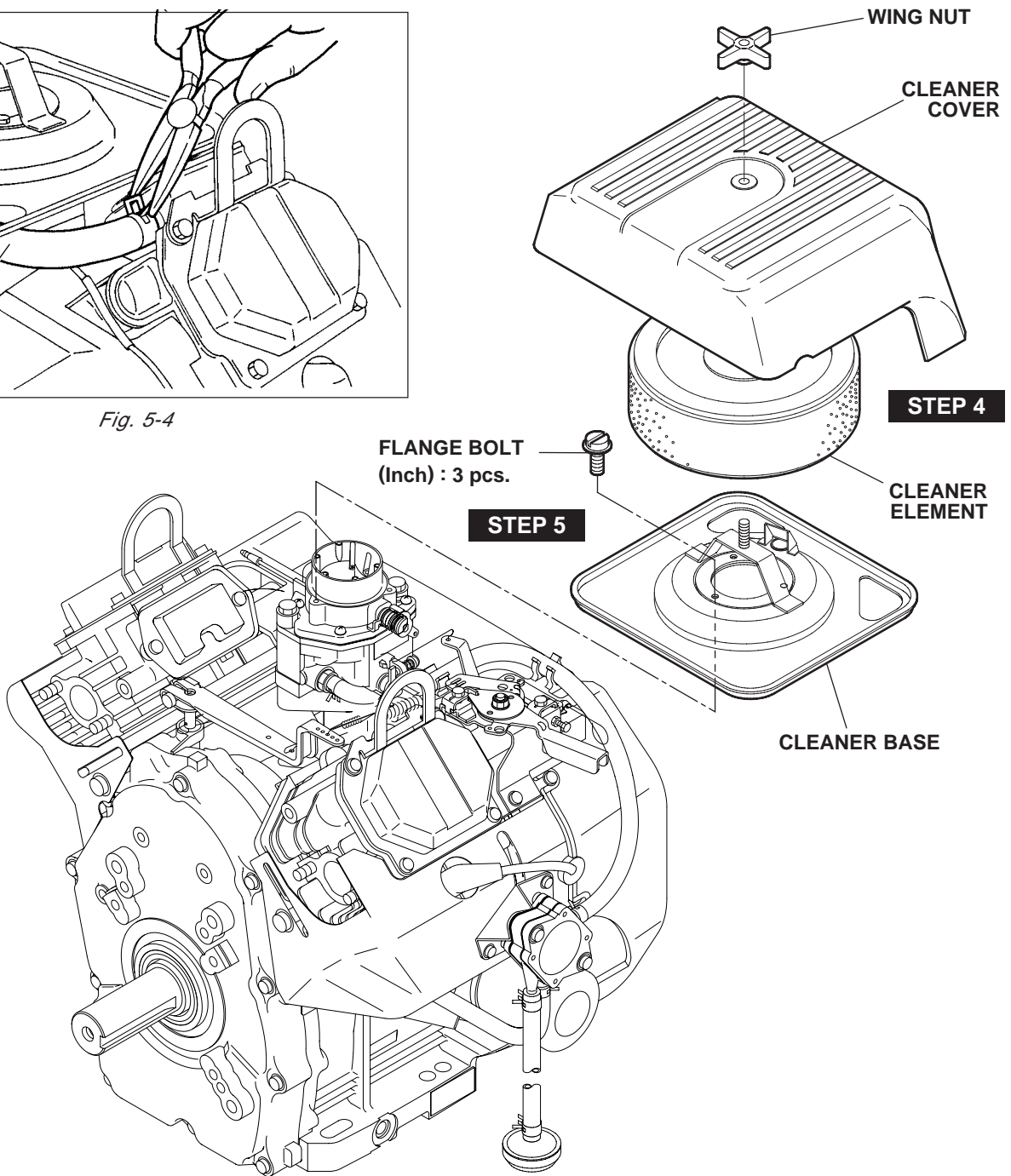

Fig. 5-3

Step	Parts to remove	Remarks and procedures	Fasteners
6	Blower housing		M6 x 12 ; 8 pcs.
7	Chock control lever and link		M6

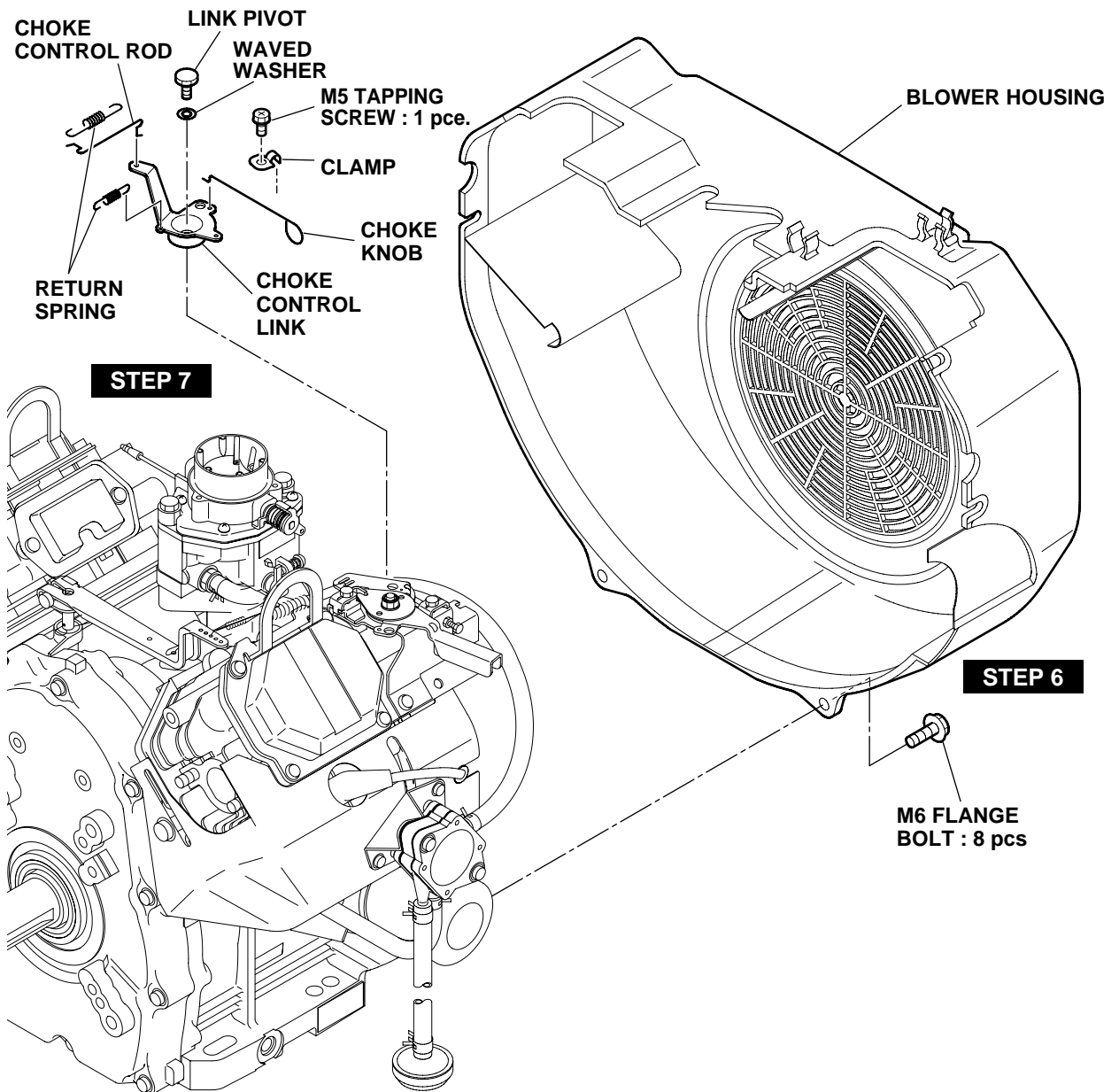

Fig. 5-5

Step	Parts to remove	Remarks and procedures	Fasteners
8	Carburetor	At first remove fuel pipe. Take out carburetor along with governor rod and rod spring.	M8 × 80 ; 2 pcs.

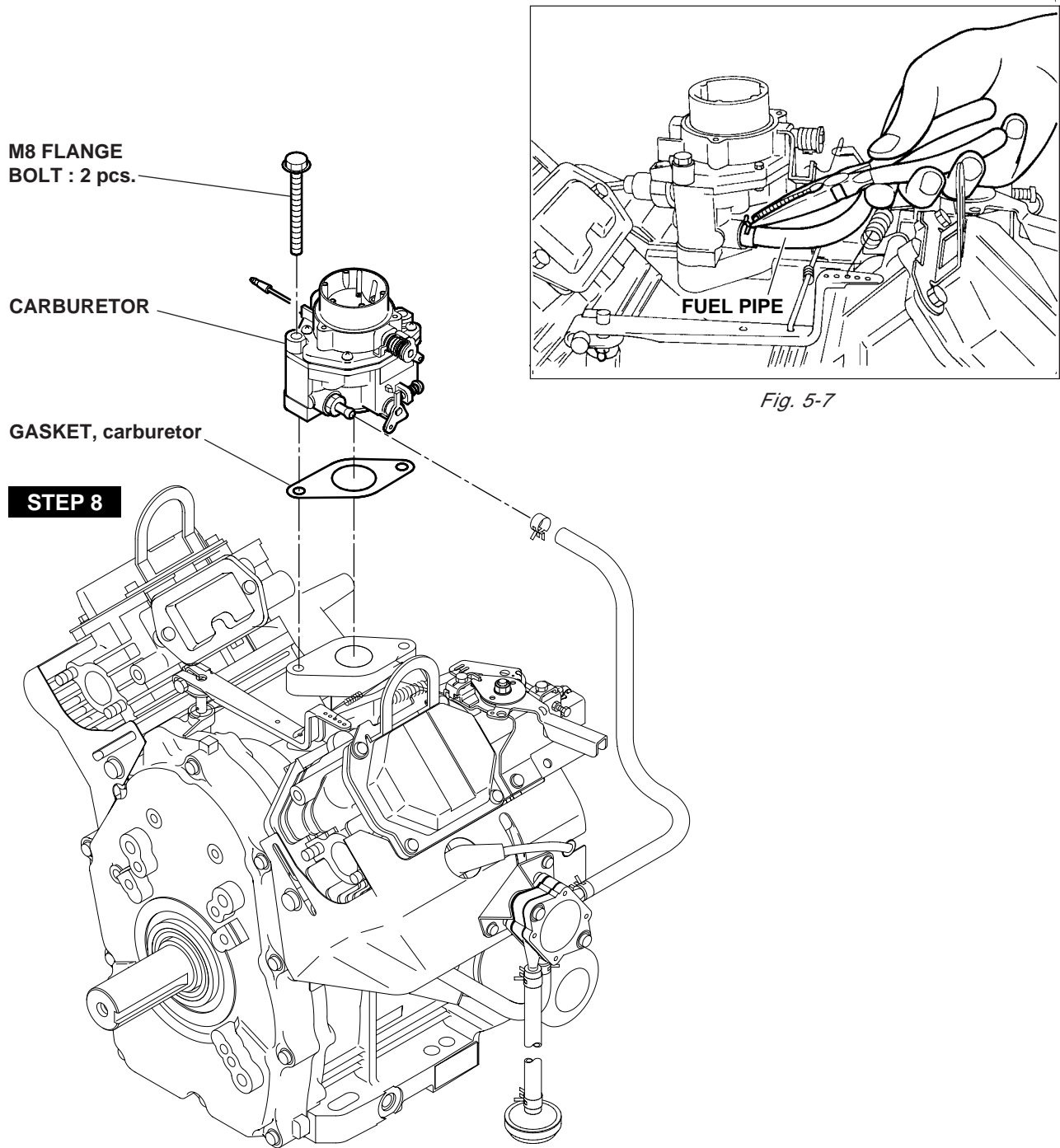

Fig. 5-6

Step	Parts to remove	Remarks and procedures	Fasteners
9	Governor lever and Speed control lever	Governor lever ; Remove bolt and take out lever. Speed control lever ; 1. Governor spring 2. Self lock nut 3. Stop plate 4. Spring washer 5. Speed control lever	M6 × 12 ; 3 pcs. M6 self-lock nut
10	Speed control bracket unit		M6 × 12 ; 3 pcs.
11	Electric starter	Remove the wires first, then remove the electric starter.	M8 × 65 ; 2 Pcs.

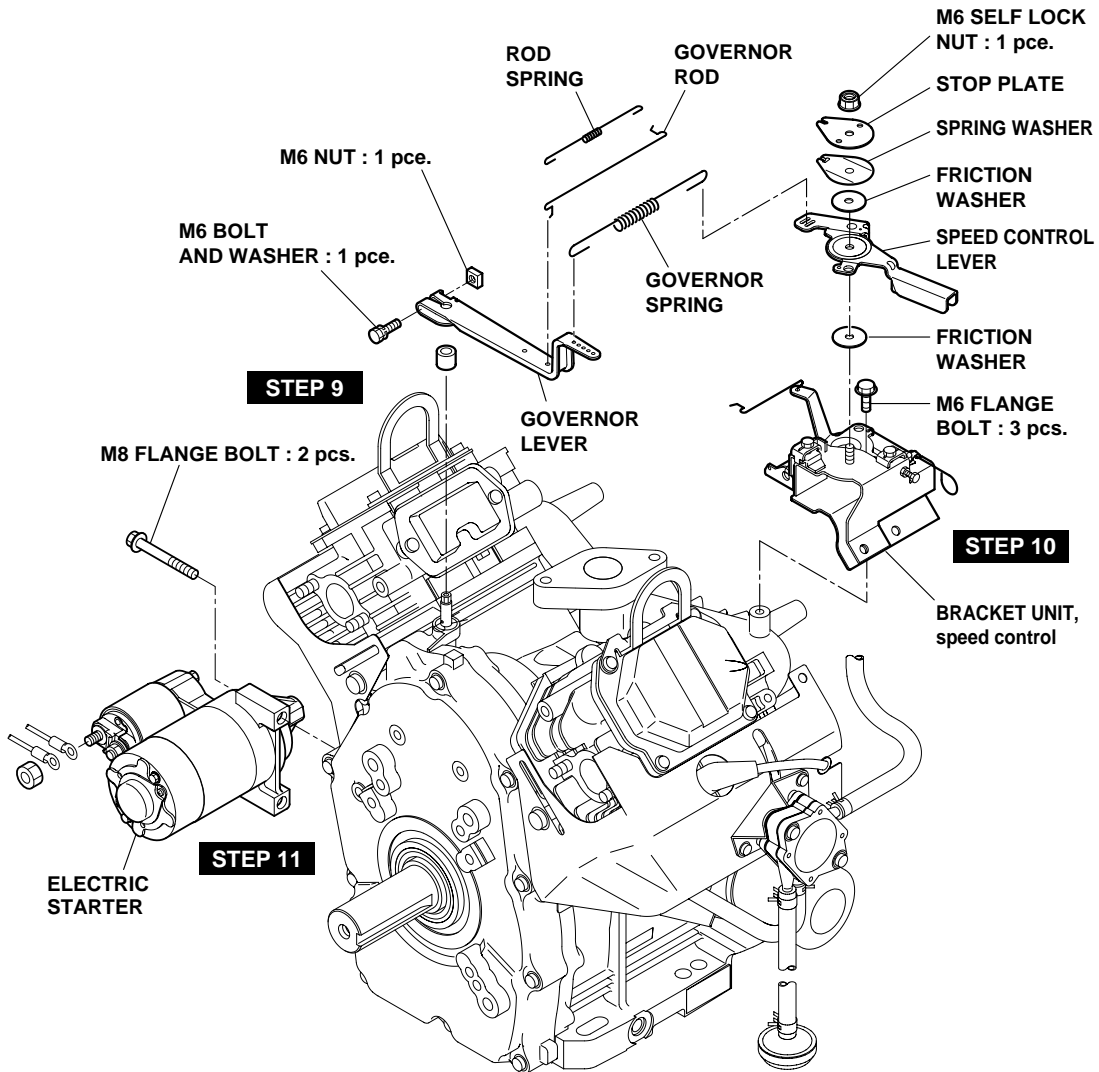

Fig. 5-8

Step	Parts to remove	Remarks and procedures	Fasteners
12	Fuel pump	Remove the pulse pipe first.	M6 × 12 ; 2 pcs.
13	Ignition coil	1. Take out plug cap. 2. Remove ignition coil. 3. Cut out stop wire fixing bands. 4. Disconnect stop wires from ignition coil.	M6 × 30 bolt & washer ; 4 pcs.

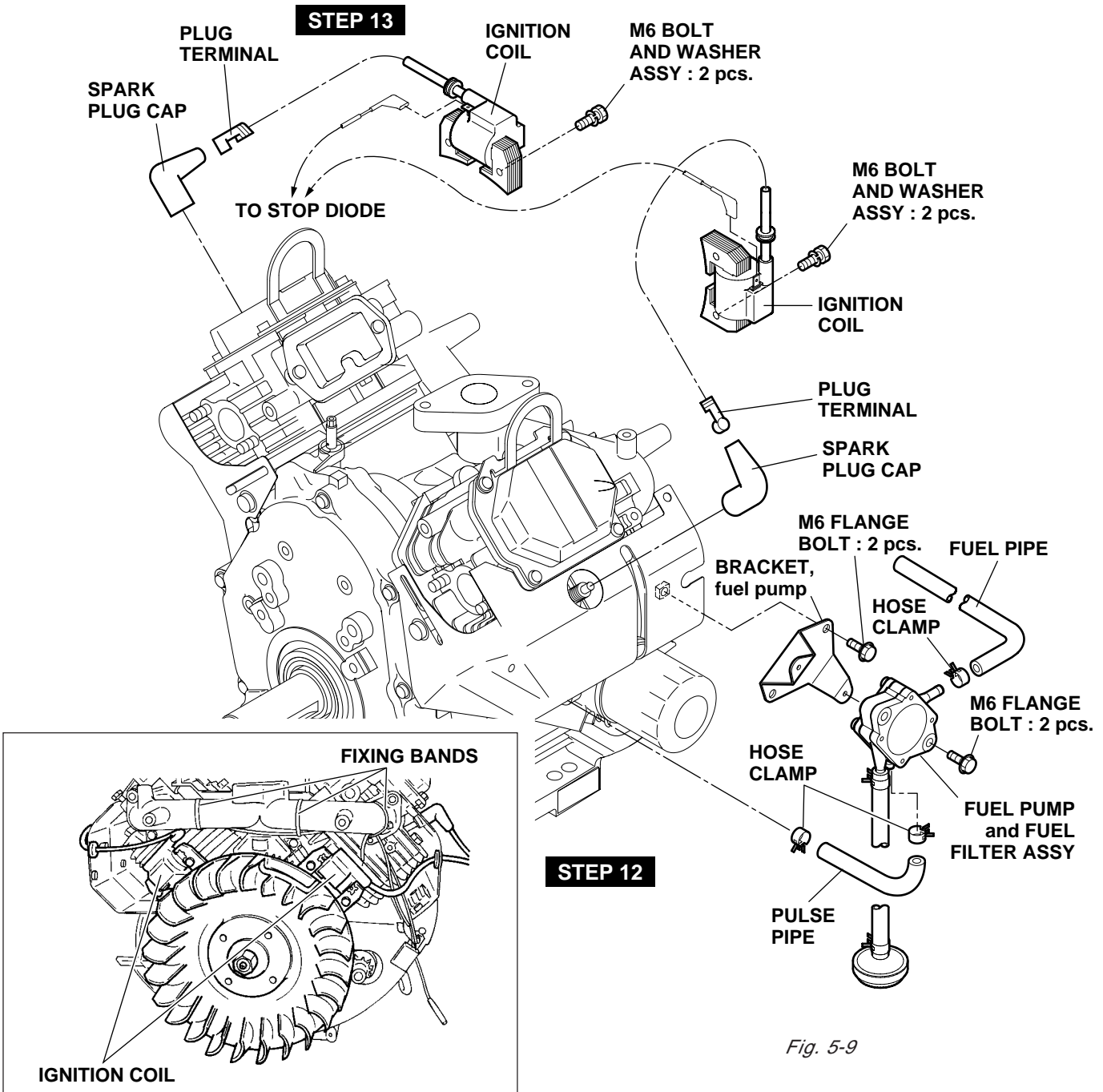

Fig. 5-9

Fig. 5-10

Step	Parts to remove	Remarks and procedures	Fasteners
14	Intake manifold		M8 flange nut ; 4 pcs.

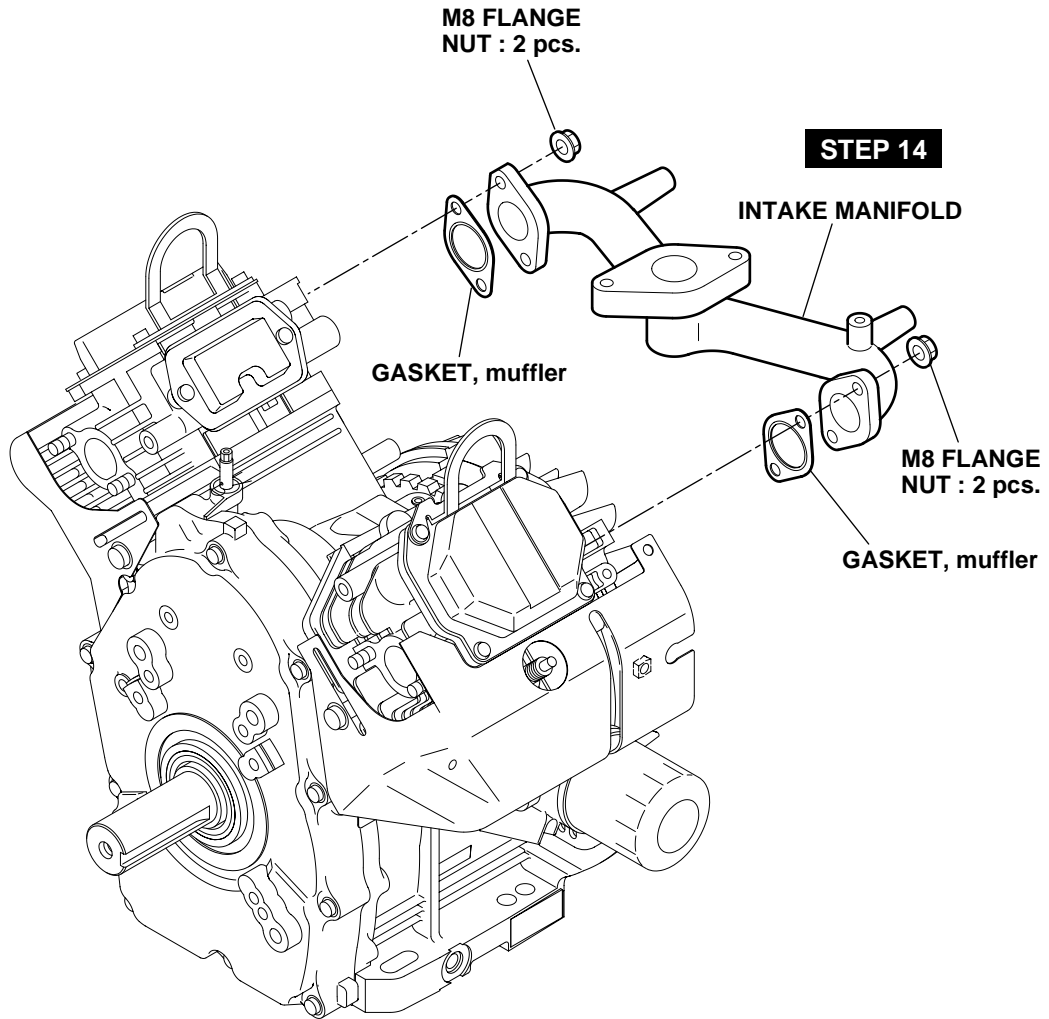

Fig. 5-11



Step	Parts to remove	Remarks and procedures	Fasteners
15	Flywheel	Remove flywheel from crankshaft by using puller.	M18 nut, washer, spring washer
16	Charge coil		M5 x 20 ; 4 pcs.

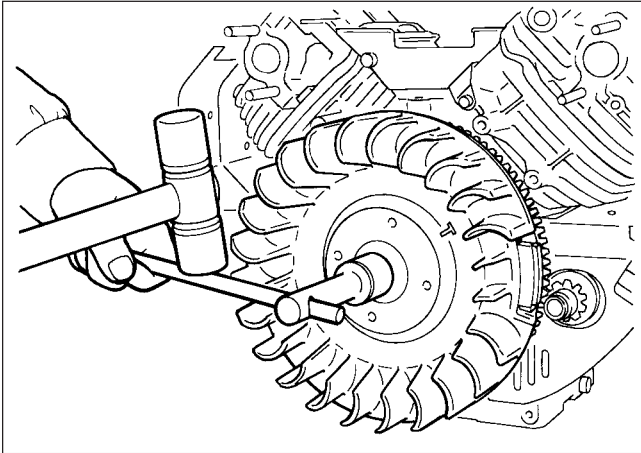

Fig. 5-13

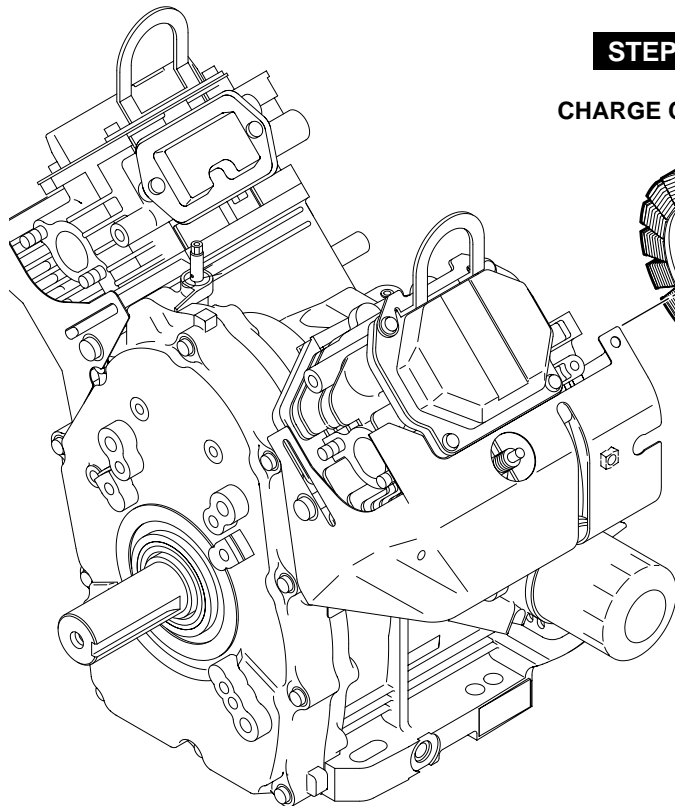

Fig. 5-12

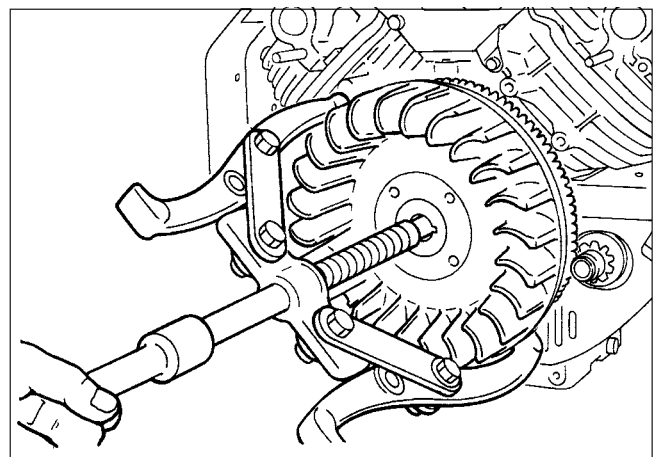
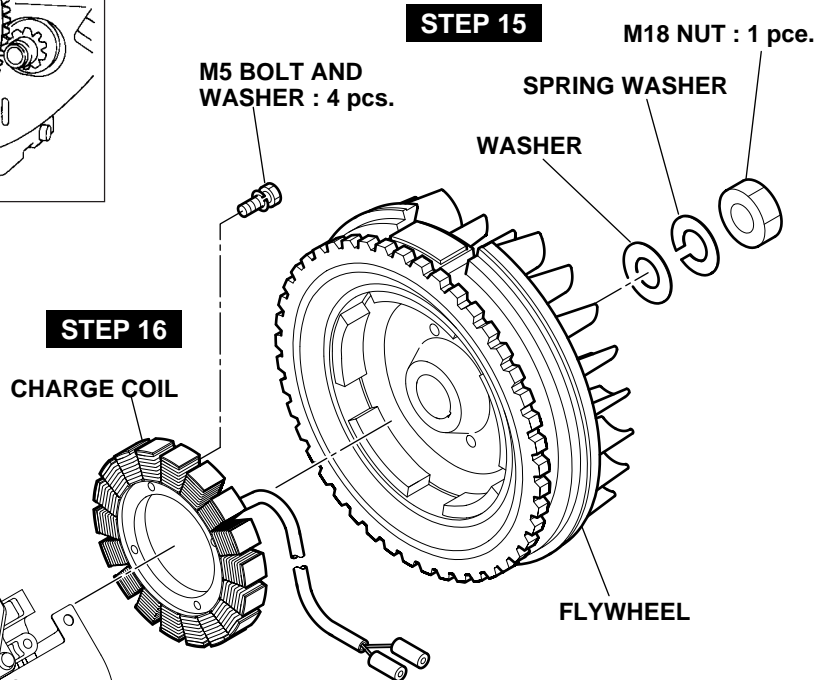

Fig. 5-14

Step	Parts to remove	Remarks and procedures	Fasteners
17	Cylinder baffles (#1, #2, #3 & #4)		M6 x 12
18	Spark plug	NGK: BP6ES or BPR6ES (or CHAMPION: N9YC or RN9YC)	

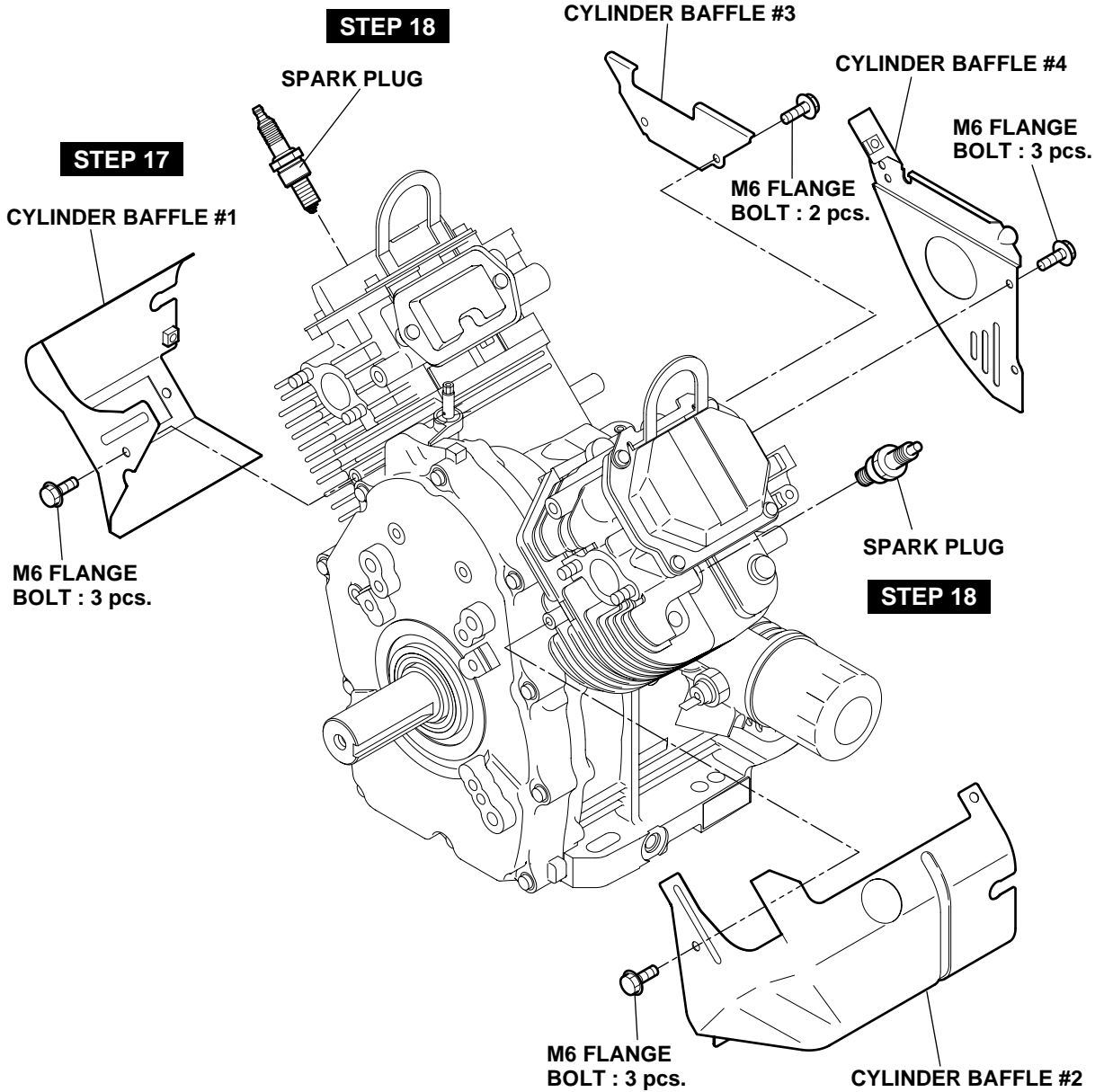

Fig. 5-15

Step	Parts to remove	Remarks and procedures	Fasteners
19	Rocker cover		M6 × 12 ; 4 pcs.
20	Cylinder head and Push rod 1. Rocker arm shaft 2. Rocker arm	Temporarily fit the flywheel, when removing rocker arm and shaft, turn and adjust flywheel at TDC with the marking "T" faced to "1" or "2" on each cylinder head. Put the marking of original position onto each push rod, rocker arm and valve for reassembly.	M10 × 65 ; 8 pcs.  M6 × 12 ; 2 pcs.

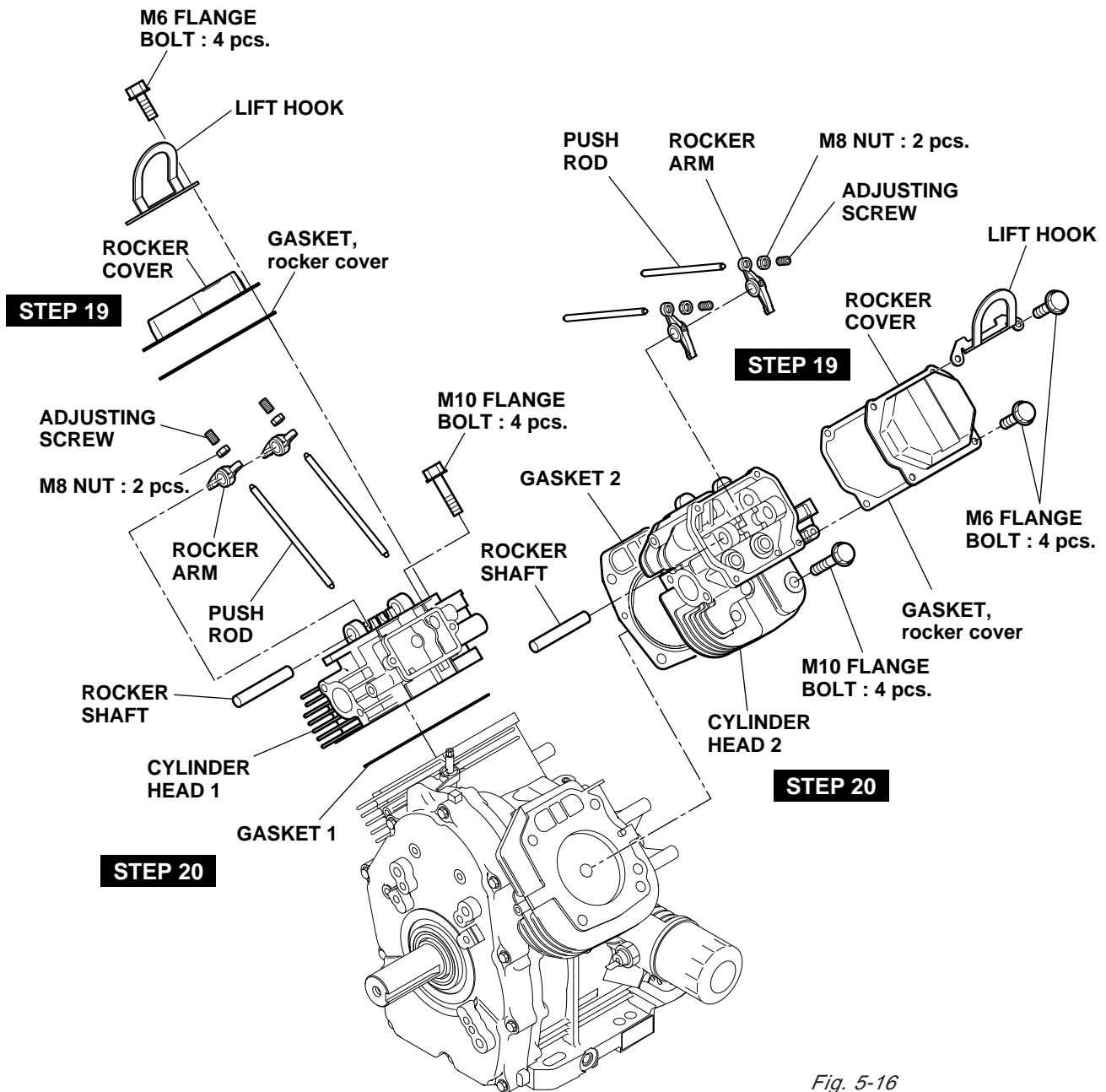

Fig. 5-16

Step	Parts to remove	Remarks and procedures	Fasteners
21	Intake & exhaust valves Breather cover Breather plate		

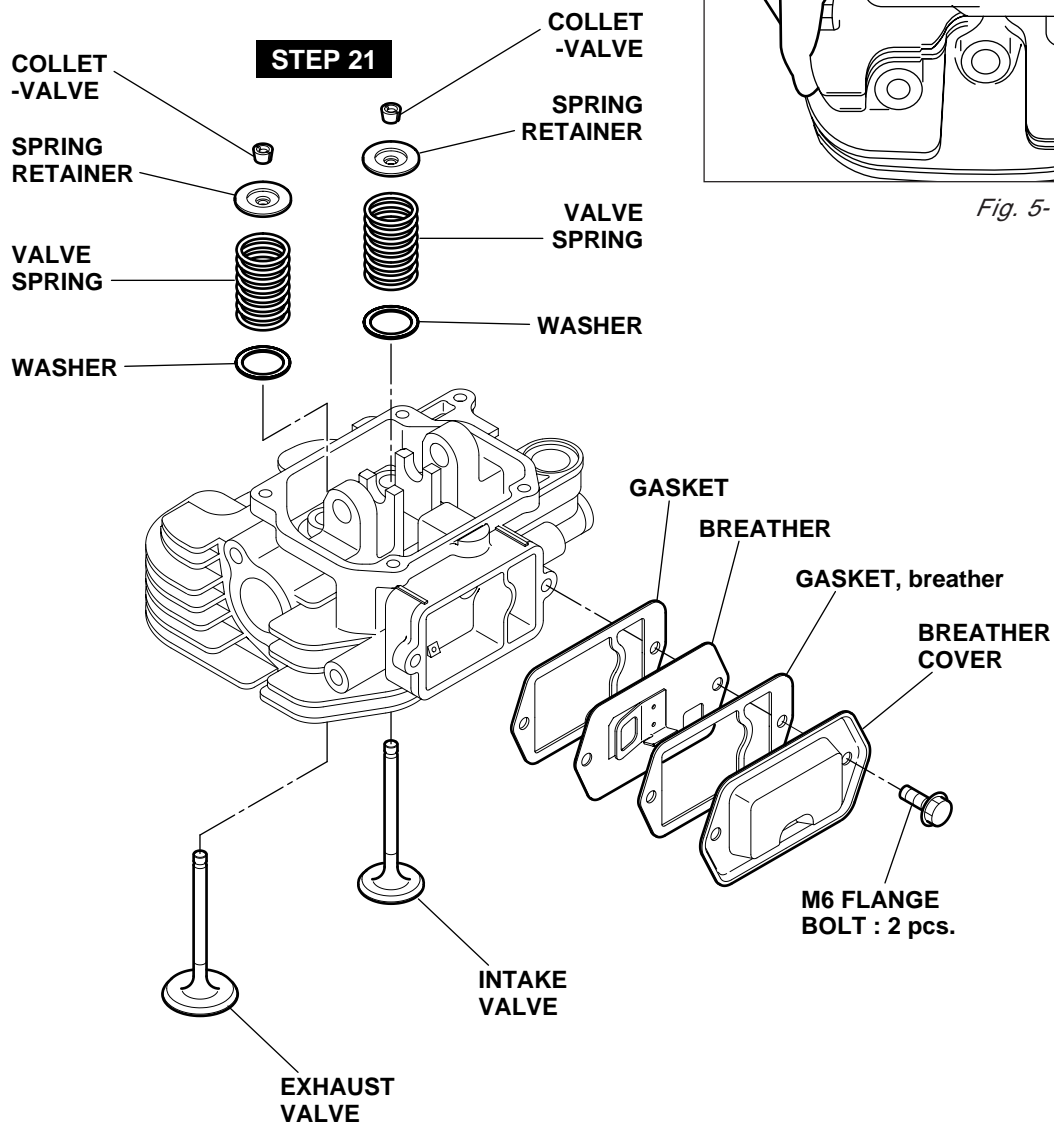

Fig. 5-17

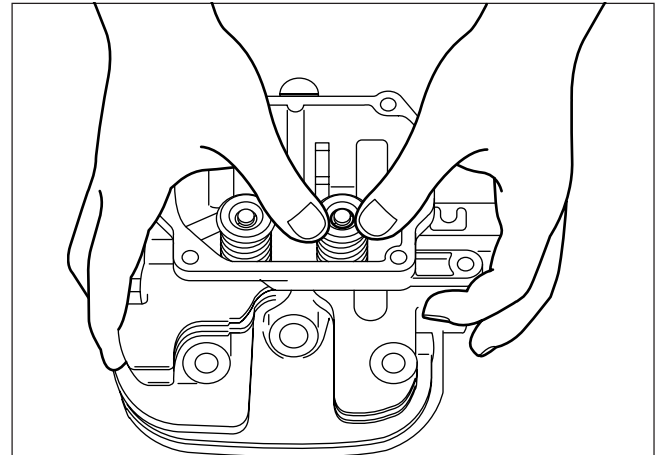

Fig. 5-18

Step	Parts to remove	Remarks and procedures	Fasteners
22	Main bearing cover	Take out key from P.T.O. shaft. Lap P.T.O. shaft with polyvinyl tape not to damage oil seal by key groove edge.	M8 × 44 ; 10 pcs.

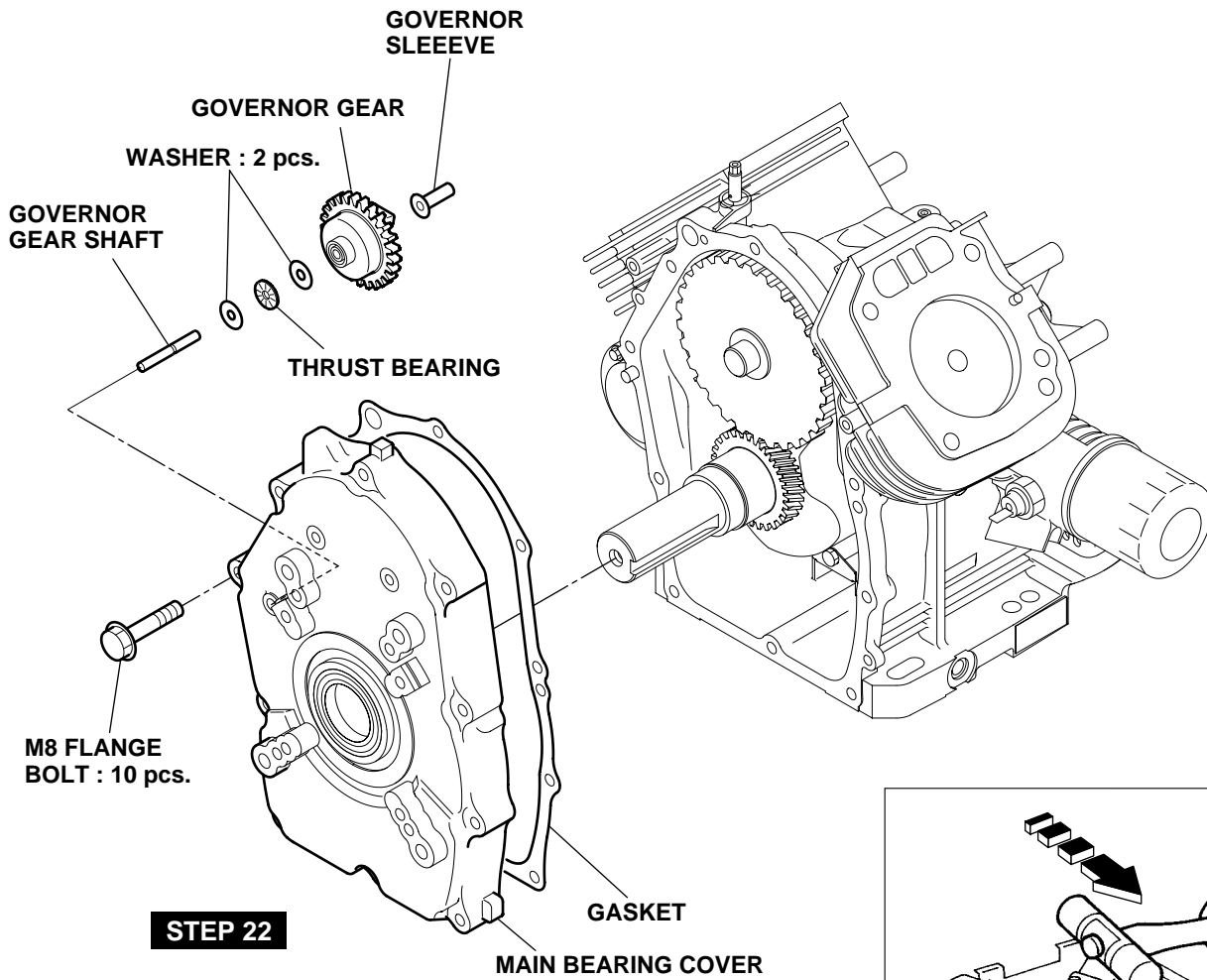

Fig. 5-19

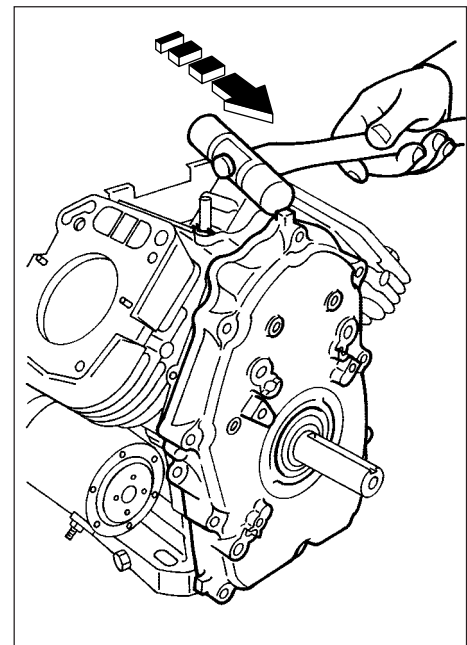

Fig. 5-20

Step	Parts to remove	Remarks and procedures	Fasteners
23	Camshaft and tappet	Mate the markings both on crankshaft gear and camshaft gear and then take out camshaft. Put the marking of original position onto each tappet for reassembly.	

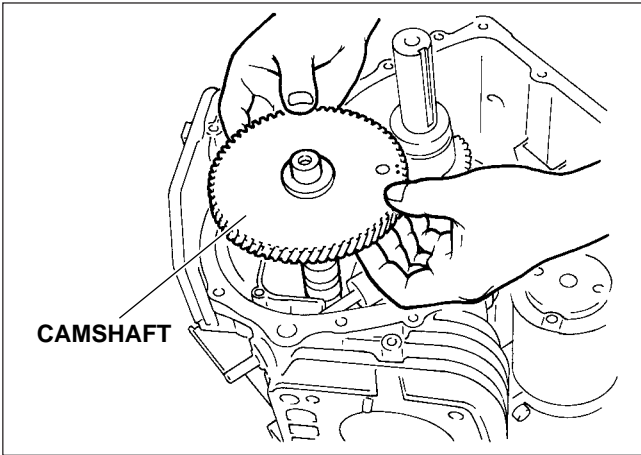

Fig. 5-22

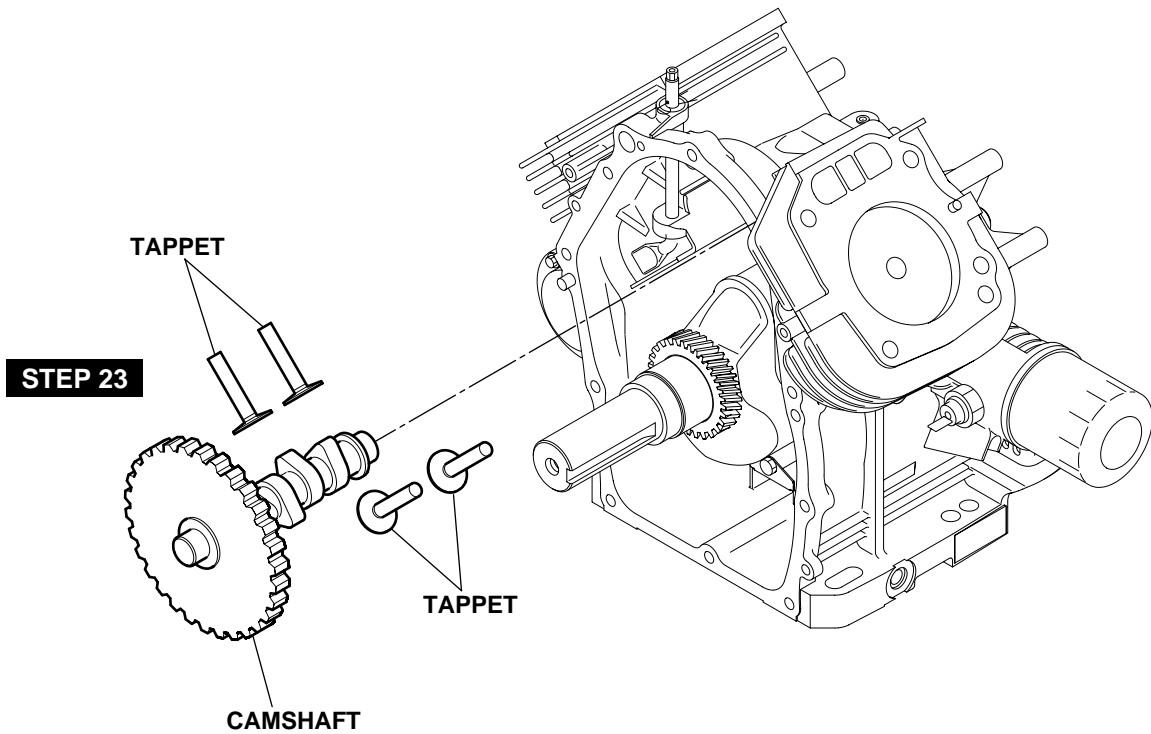

Fig. 5-21

Step	Parts to remove	Remarks and procedures	Fasteners
24	Piston and Connecting rod *Piston pin clip *Piston pin *Piston rings	1. Remove connecting rod bolts. 2. Take out connecting rod cap. 3. Push the connecting rod upwards and take out along with piston.  Put the marking of original position onto each piston, ring clip, piston pin, connecting rod and cap for reassembly.	M8 ; 4 pcs.
25	Crankshaft	1. Remove key from crankshaft. 2. Remove crankshaft tapping at the flywheel end using plastic hammer.	

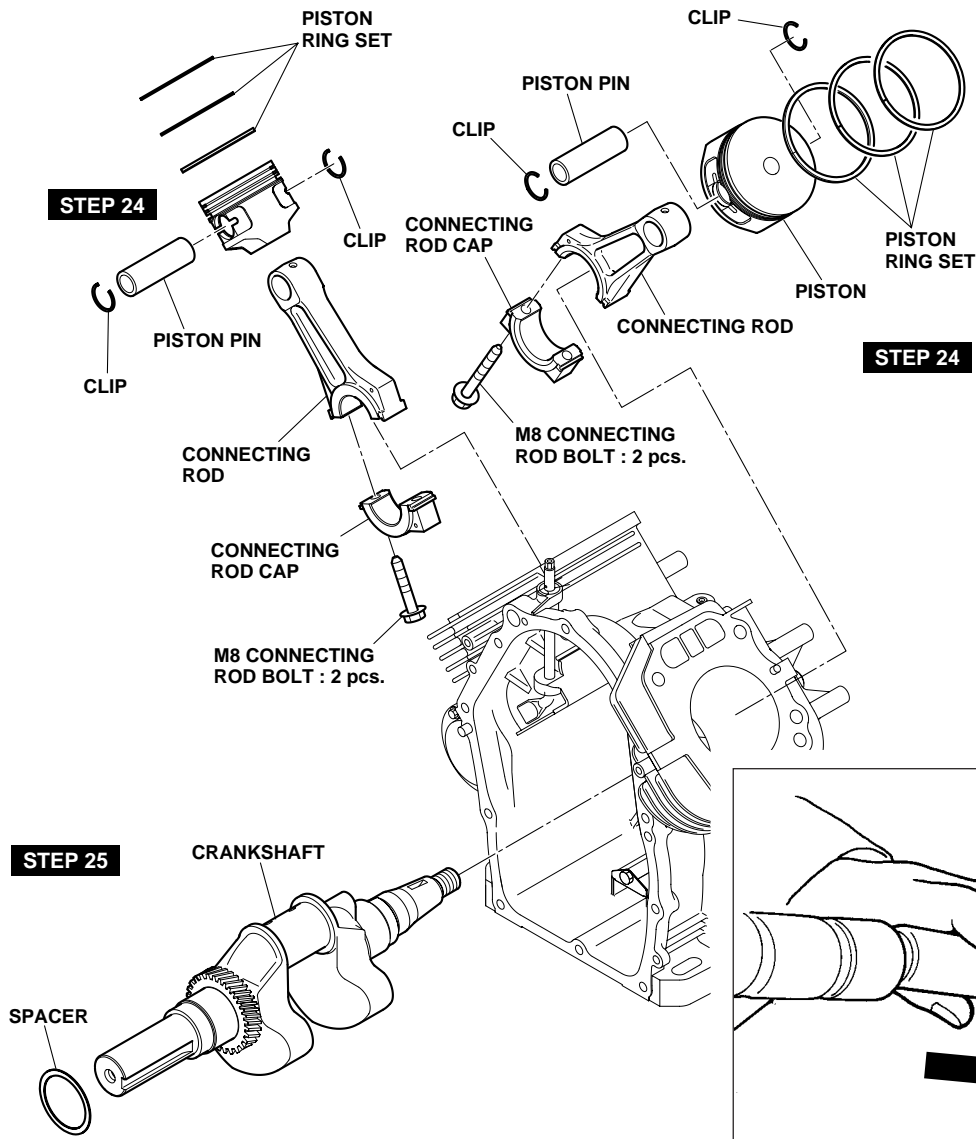

Fig. 5-23

Fig. 5-24

Step	Parts to remove	Remarks and procedures	Fasteners
26	Crankcase *Oil pump *Oil filter *Oil pressure switch *Oil pump filter *Oil relief spring & ball *Governor lever shaft		M6 × 18 ; 4 pcs.  10-32 × 11 (Inch)

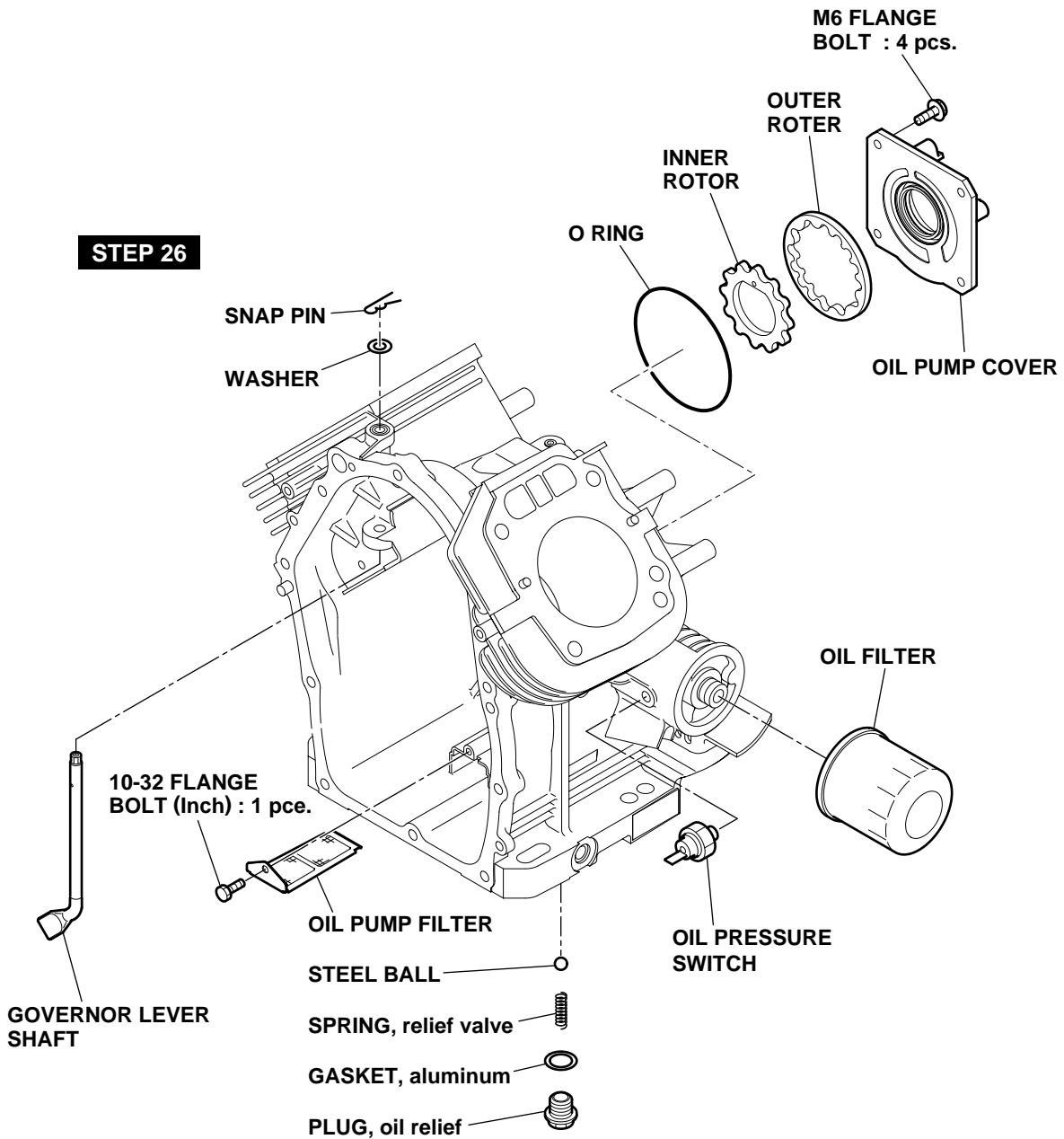

Fig. 5-25



## 5-4 REASSEMBLY PROCEDURES

### 5-4-1 PRECAUTIONS FOR REASSEMBLY

- 1) Clean parts thoroughly before reassembly.  
Pay most attention to cleanliness of piston, cylinder, crankshaft, connecting rod and bearings.
- 2) Scrape off all carbon deposits from cylinder head, piston top and piston ring grooves.
- 3) Check lip of oil seals. Replace oil seal if the lip is damaged. Apply oil to the lip before reassembly.
- 4) Replace all the gaskets with new ones.
- 5) Replace keys, pins, bolts, nuts, etc., if necessary.
- 6) Torque bolts and nuts to specification referring to the "TORQUE SPECIFICATIONS".
- 7) Apply oil to rotating and sliding portions.
- 8) Check and adjust clearances and end plays where specified in this manual.

### 5-4-2 Pre-assembly

#### A. CRANKCASE

- (1) Fix oil pump filter in position.
- (2) Insert ball and spring into the oil relief valve hole and tighten plug to the specified torque.

**Tightening Torque : 11.8 - 14.7 N-m (150 - 250 kg-cm, 10.9 - 18.1 ft-lb.)**

- (3) Fit governor lever shaft with clip.
- (4) Tighten oil drain plugs on both side of crankcase.

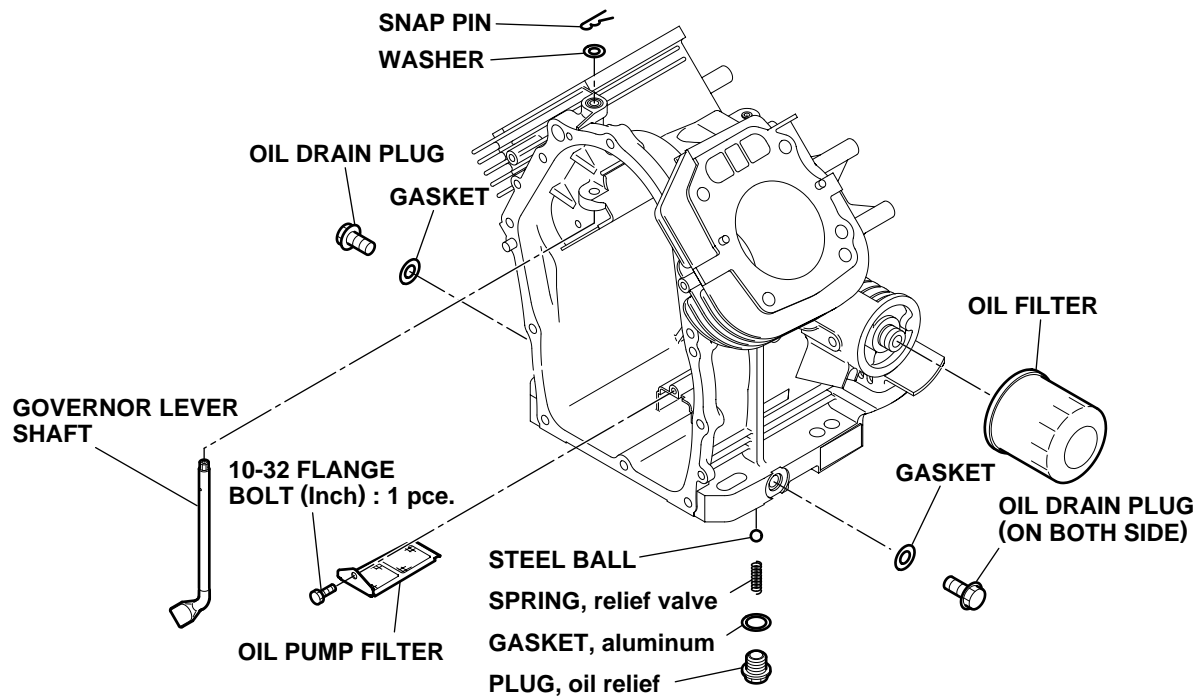

Fig. 5-26

## B. CYLINDER HEAD, VALVES and ROCKER ARM

### NOTE ;

- \* Clean valves and wash cylinder head thoroughly.
- \* Remove carbon and gum deposits from the valves, seats, ports and guides.
- \* Inspect valves, valve seats and valve guides.
- \* Replace valves that are badly burned, pitted or warped.
- \* Valve guides should be replaced when valve stem clearance exceeds specifications.

(Refer to SERVICE DATA for clearance specifications. )

If exceeds, draw valve guides out and press new guides in.

After replacing valves and guides, lap valves in place until a uniform ring shows around the face of the valve.

(1) Attach oil seal only onto intake valve guide.

(2) Apply oil to washer, valve spring and valve stem.

Place cylinder head on flat table and install washer, valve spring, valve and spring retainer.

(3) Install rocker arm and shaft.

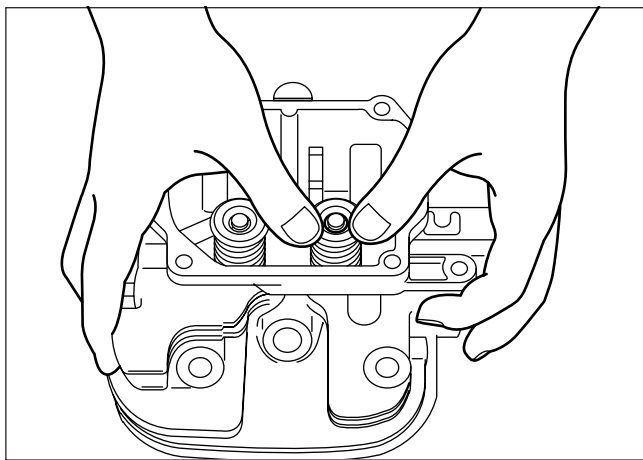

Fig. 5-28

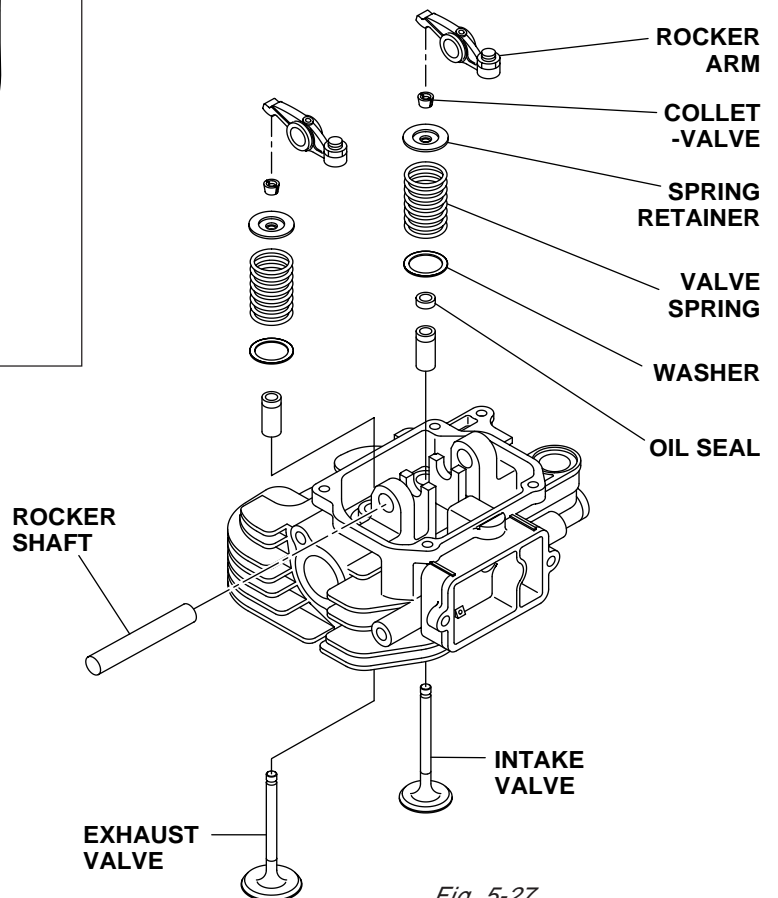

Fig. 5-27

### C. PISTON and CONNECTING ROD

(1) Install oil ring first, then second ring and top ring. Spread ring only far enough to slip over piston and into correct groove. Use care not to distort ring.

**NOTE ;**

- \* Install second ring with punched mark beside the gap on the top side.
- \* Top ring can be fit either way.
- \* As for oil ring, rails should be placed on and below the expander.

(2) Apply enough oil to small end of connecting rod and piston pin, and fix connecting rod to piston with piston pin.  
 (3) Use clips on the both side of the piston pin to secure piston pin in position.

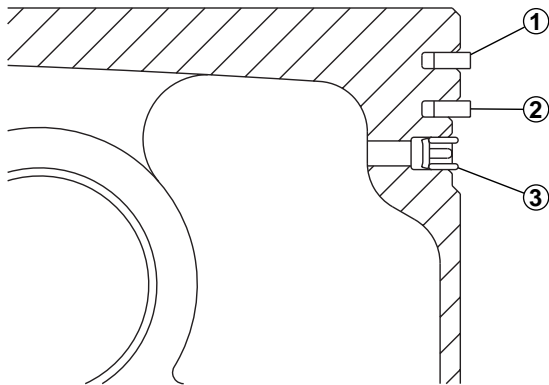

①	TOP RING	BARREL	
②	SECOND RING	TAPER	
③	OIL RING	COMBINATION RING	

Fig. 5-29

### D. Main bearing cover and governor gear

(1) Insert washer into governor gear shaft.  
 (2) Insert governor gear along with sleeve into governor gear shaft.

**Note:**

**If replace governor gear, you must replace with new one.**

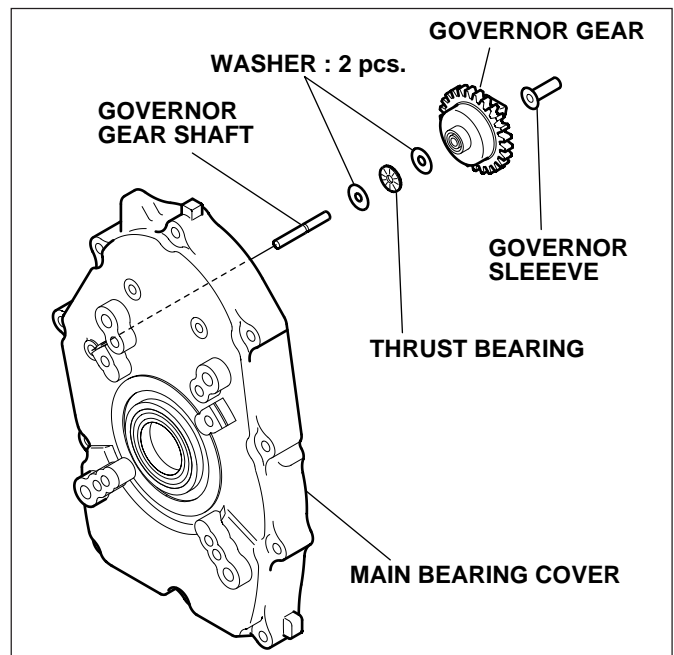

Fig. 5-30

### 5-4-3 Re-assembly

#### 1) CRANKSHAFT

Install crankshaft onto crankcase.

**Note:**

**Apply enough oil to bearing portion of crankcase. For easy installation, put crankcase on box or wood blocks.**

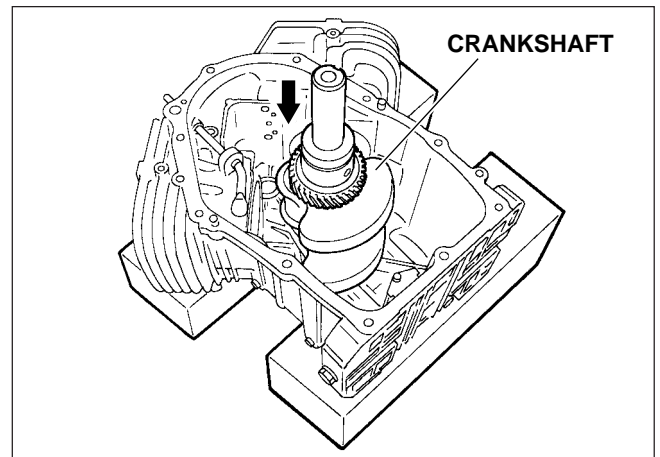

Fig. 5-31

#### 2) PISTON and CONNECTING ROD

(1) Install piston and connecting rod assembly into cylinder by using a piston ring compressor to hold piston rings.

**Note:**

\* The "1" mark of the connecting rod for #1 cylinder and "2" mark for #2 cylinder should be faced to the main bearing cover side when assembled.

\* Apply enough oil to piston rings, connecting rod bearings (large end) and cylinder bore before assembly.

\* Set gaps of piston rings as shown in the illustration.

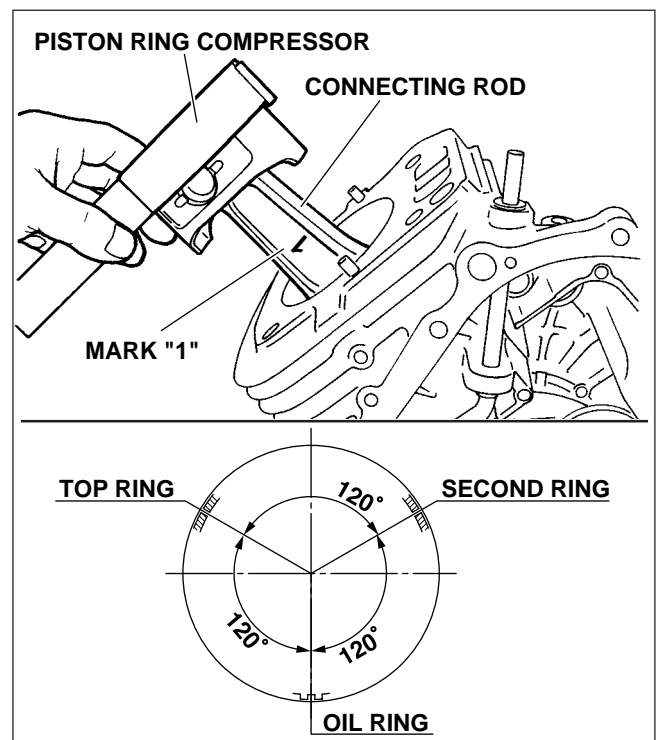

Fig. 5-32

(2) Temporary fit key and flywheel and turn crankshaft to BTDC (bottom dead center). Lightly tap the top of piston until large end of the rod meet the pin portion of crankshaft.

(3) Set connecting rod cap to connecting rod with the alignment marks mated and the clinching portion clinched. Tighten bolts to the specified torque.

**Tightening Torque : 22.1 - 27.0 N-m  
(225 - 275 kg-cm)  
(16.3 - 19.9 ft-lb.)**

(4) Check for free movement of piston and connecting rod by turning crankshaft slowly.

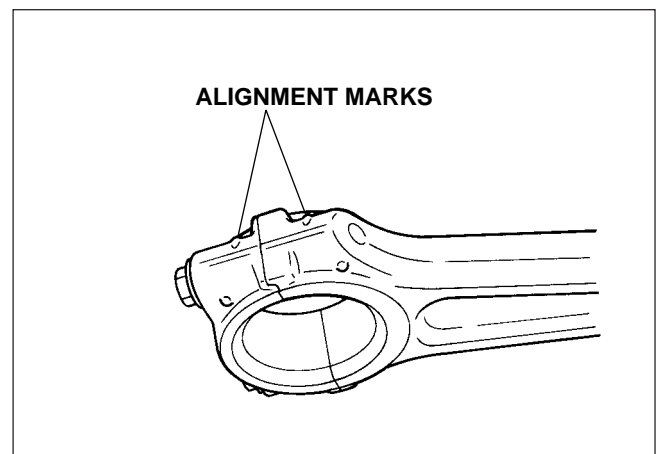

Fig. 5-33

### 3) TAPPET and CAMSHAFT

- (1) Apply oil to tappets and install in their original position. Push in fully to avoid damage during camshaft installation.
- (2) Lubricate bearing surfaces of camshaft. Install camshaft into the crankcase with the timing mark on both crankshaft gear and camshaft aligned.

**CAUTION :**  
**Incorrect alinement will cause malfunction of the engine.**

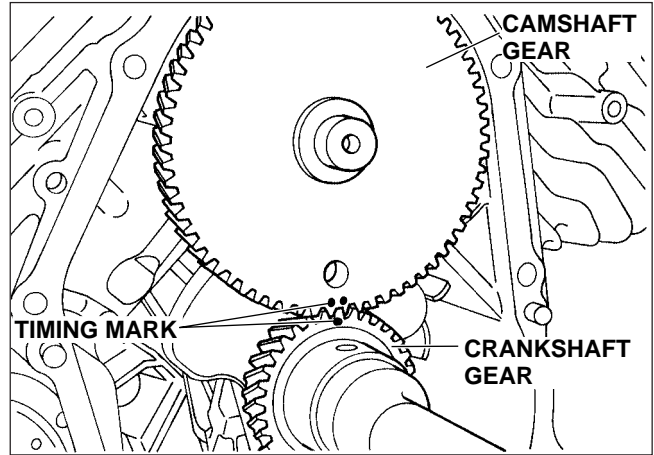

Fig. 5-34

### 4) Adjust side clearance

Measure end play of crankshaft and camshaft.  
 Adjust end play to "0" using the proper spacer.

SPACER (mm) = "A" + 0.36 - "B" (①-②)

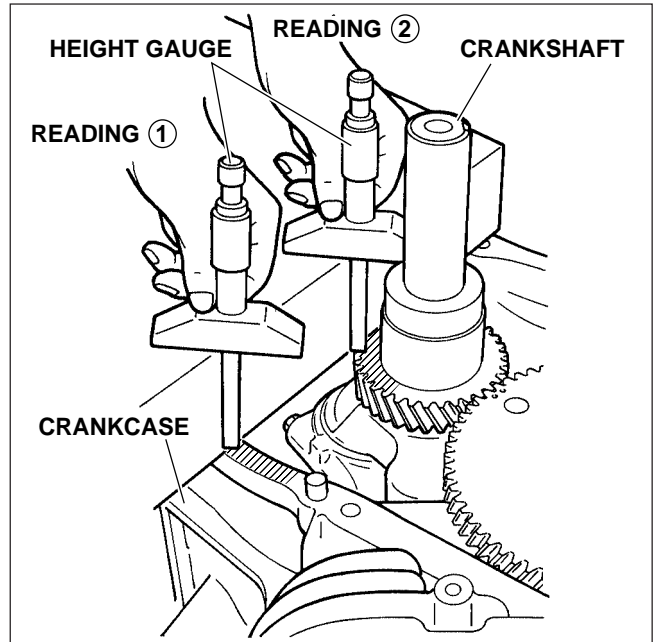

Fig. 5-35

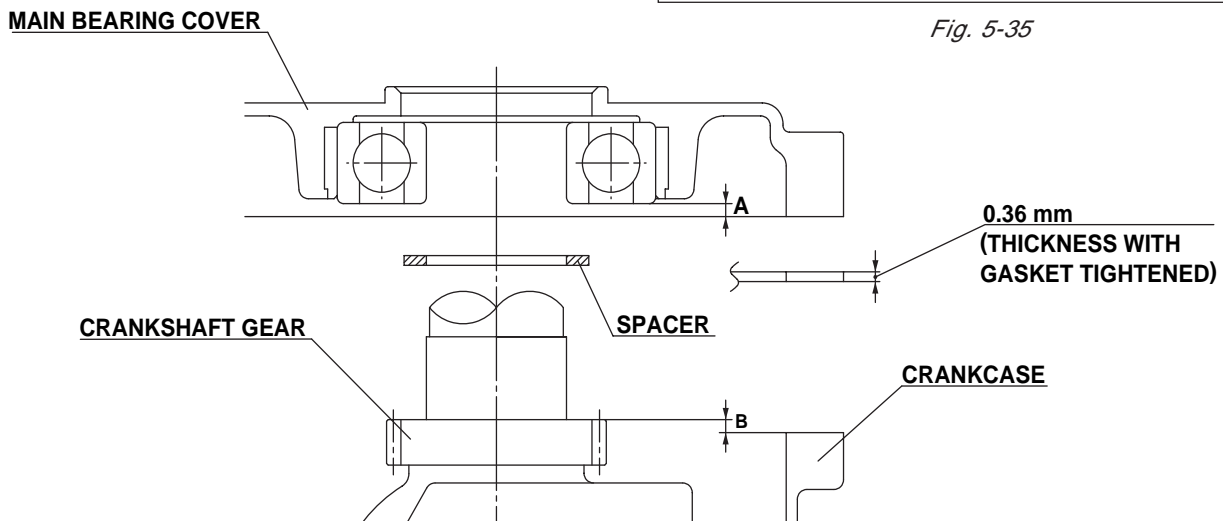
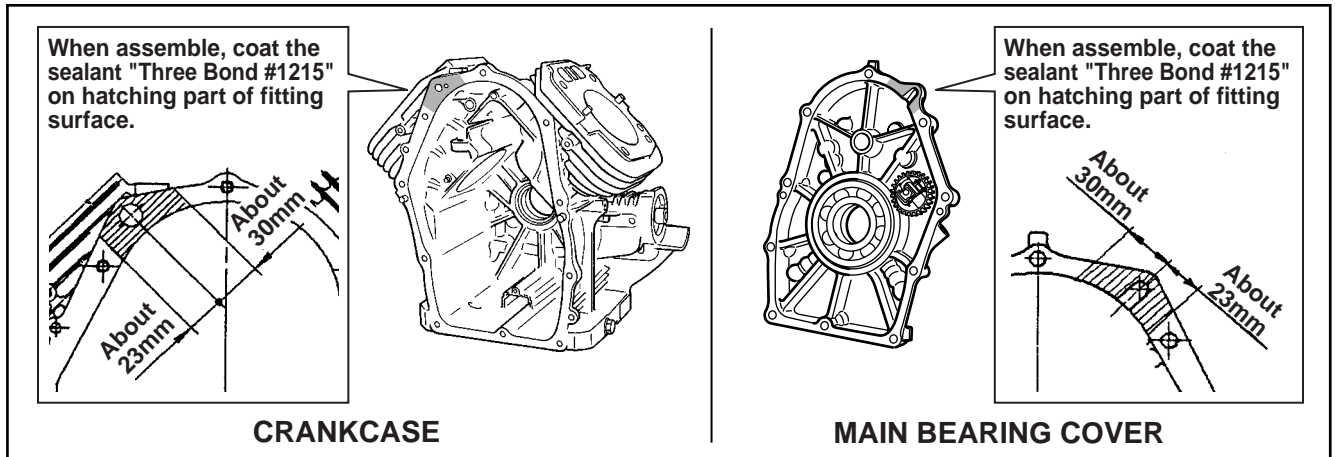



Fig. 5-36

## 5) MAIN BEARING COVER

- (1) Put a oil seal guide onto PTO shaft portion to avoid damaging the main bearing cover oil seal.
- (2) Coat the sealant "Three Bond #1215" partly on both fitting surfaces of crankcase and main bearing cover.



- (3) Place gasket onto the mating surface of crankcase.
- (4) Lubricate oil seal lip portion and bearing surfaces, and install main bearing cover.  
Tighten bolts evenly to the specified torque.

	Bolt	N·m	kgf-cm	ft-lb.	Affected engine serial No.
Tightening Torque	 7T Bolt	16.7 - 18.6	170 - 190	12.3 - 13.7	~ 6010444
	 9T Bolt	22.5 - 27.5	230 - 280	16.6 - 20.2	6010445 ~

### NOTE ;

- \* Before installing main bearing cover, be sure to check the installation of governor lever shaft and oil pump filter in the crankcase in position.
- \* Tap cover with a soft hammer until tatching the crankcase mating surface, engaging with governor gear and camshaft gear properly.
- \* Rotate crankshaft slowly to check for smooth operation and side clearance.

## 6) OIL PUMP and COVER

- (1) Apply oil to inner and outer rotors of oil pump and attach them in position.
- (2) Set O-ring in position.
- (3) Install oil pump cover with the allow marking upwards.

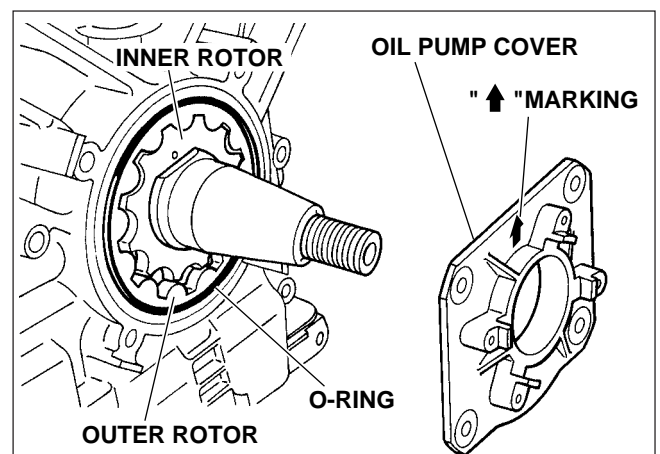

Fig. 5-37

## 7) CYLINDER HEAD

### NOTE ;

**Be sure to check dwell pin, and replace with new one if damaged.**

- (1) Place new head gasket onto crankcase.
- (2) Install #1 and #2 cylinder heads. Tighten bolts evenly in steps to the specified torque.

### Tightening torque

	1st step	2nd step	Final step
N · m	20	30	33.3 - 41.2
kg - cm	200	300	340 - 420
ft - lb.	14.4	21.6	24.6 - 30.4

## 8) PUSH ROD

- (1) Rotate crankshaft to the position in the no lifted condition of tappet.
- (2) Be sure to loose the rocker arm adjust screw.
- (3) Insert push rods into the concave portion of tappet and set the other end to the concave portion of rocker arm adjust screw with valve spring depressed.
- (4) Temporally tighten adjust screw.

## 9) VALVE CLEARANCE ADJUSTMENT

NOTE : Temporally fit the flywheel in position for easy operation.

- (1) Rotate crankshaft clockwise to the TDC (top dead center) of compression stroke by matching the mark "T" of flywheel with the mark "1" of #1 cylinder head.
- (2) Loosen lock nut on rocker arm and turn adjusting screw to adjust the clearance between rocker arm and valve stem end, and then tighten lock nut to the specified torque.

**Valve Clearance :  $0.10 \pm 0.015$  mm ( $0.0039 \pm 0.0006$  in) (Cold condition)**

**Tightening Torque : 9.8 - 13.7 N-m  
(100 - 140 kg-cm)  
(7.2 - 10.1 ft-lb.)**

- (3) Adjust valve clearance of #2 cylinder side in the same manner.
- (4) Rotate crankshaft several times and be sure to check valve clearance again. Adjust valve clearance if necessary.

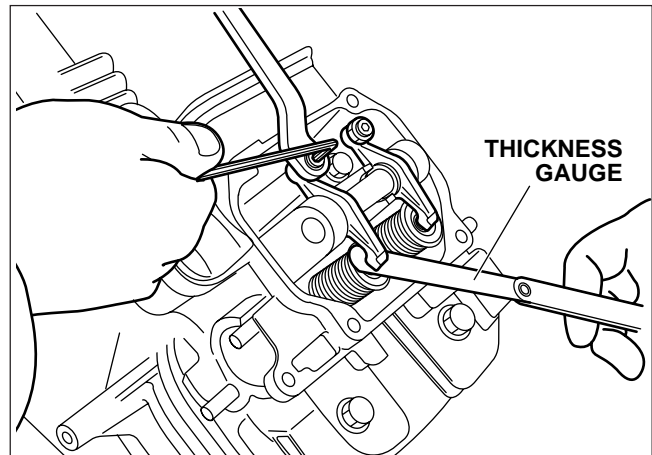
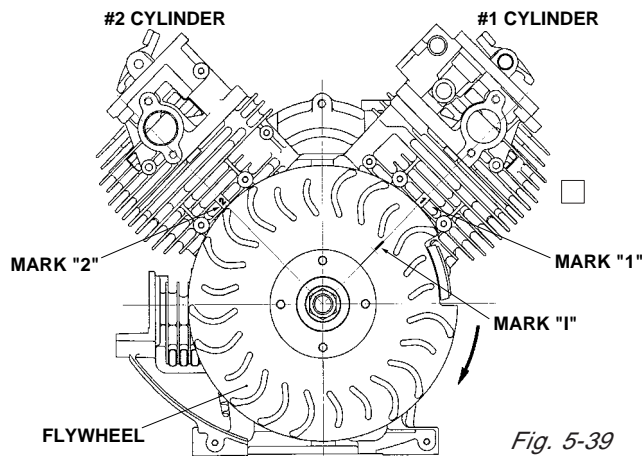

Fig. 5-38

## 10) ROCKER COVER

Install rocker cover with new gasket.

**Tightening Torque : 2.9 - 4.9 N-m (30 - 50 kg-cm, 2.2 - 3.6 ft-lb.)**

## 11) BREATHER PIPE and COVER

Attach breather plate (breather valve) and breather cover to crankcase using proper gaskets.

Put breather plate in such position as its reed valve opens outside.

**Tightening Torque : 2.9 - 4.9 N-m  
(30 - 50 kg-cm)  
(2.2 - 3.6 ft-lb.)**

### Note:

**Never tighten the bolts over the specified torque, or gasket is damaged and cut. Replace gaskets with new ones if they are torn or damaged.**

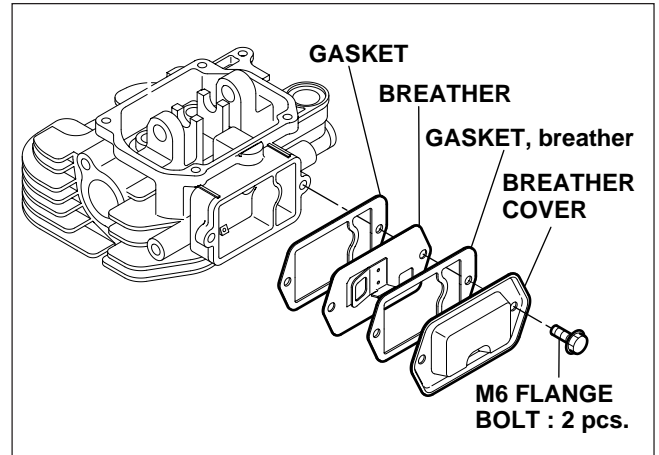

Fig. 5-40

## 12) SPARK PLUG

Install spark plug to each cylinder head.

**Spark plug : NGK - BP6ES or BPR6ES (CHAMPION - N9YC or RN9YC)**

### Tightening Torque :

**New plug - 11.8 - 14.7 N-m (120 - 150 kg-cm, 8.7 - 10.8 ft-lb.)  
Current plug - 22.5 - 26.5 N-m (230 - 270 kg-m, 16.6 - 19.5 ft-lb.)**

## 13) CHARGE COIL

Install charge coil with the wiring located at 2-o'clock position.

**Tightening Torque : 3.1 - 4.1 N-m  
(30 - 40 kg-cm)  
(2.2 - 2.9 ft-lb.)**

## 14) STARTER MOTOR

Install starter motor.

**Tightening Torque : 16.7 - 18.6 N-m  
(170 - 190 kg-cm)  
(12.3 - 13.7 ft-lb.)**

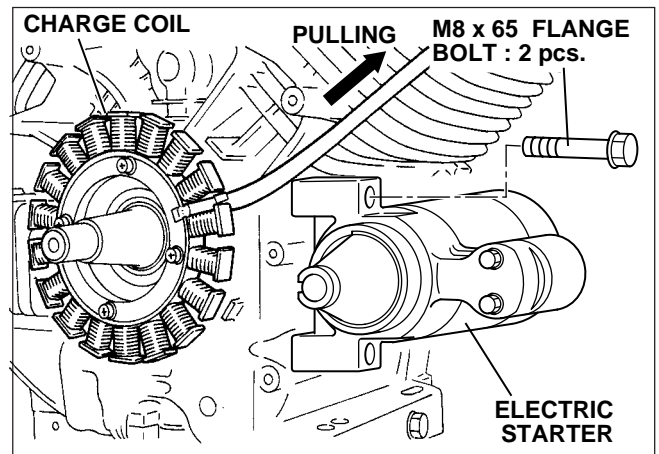

Fig. 5-41



### 15) CYLINDER BAFFLE

Attach cylinder baffle #3 and #4.

### 16) INTAKE MANIFOLD

Set gasket (stainless steel) onto both #1 and #2 cylinder head and install intake manifold.

**Tightening Torque : 16.7 - 18.6 N-m  
(170 - 190 kg-cm)  
(12.3 - 13.7 ft-lb.)**

### 17) SPEED CONTROL BRACKET and CYLINDER BAFFLE

Install speed control bracket onto intake manifold and attach cylinder baffle #1 and #2.

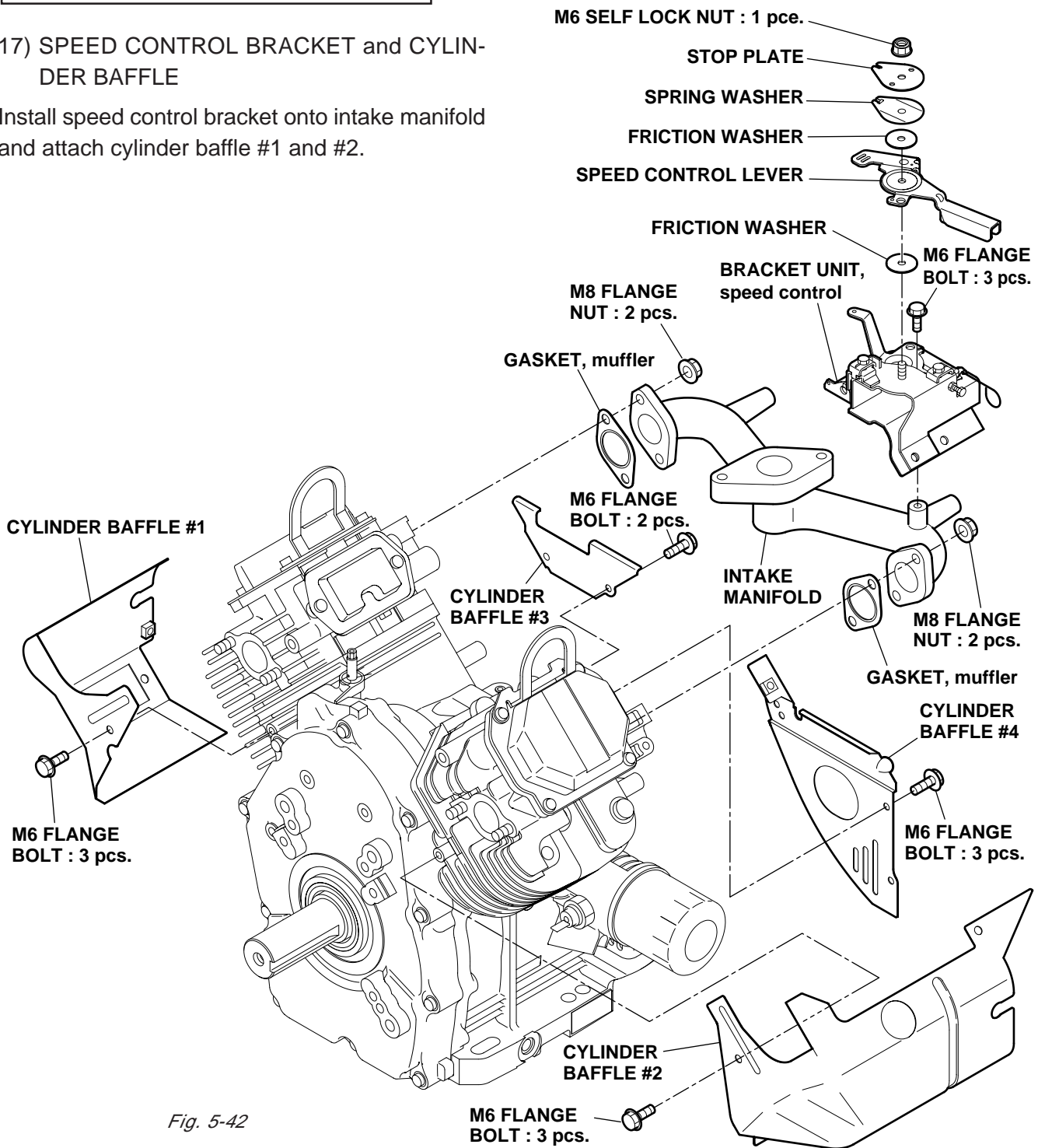

Fig. 5-42

## 18) FLYWHEEL

- (1) Put woodruff key in the keyway of crankshaft.
- (2) Wipe off oil and grease thoroughly from tapered portion of crankshaft and flywheel center hole.
- (3) Install flywheel to crankshaft and tighten flywheel nut with spring washer and washer.

**Tightening Torque : 83.3 - 93.1 N-m**  
**(850 - 950 kg-cm)**  
**(61.5 - 68.7 ft-lb.)**

## 19) IGNITION COIL

Temporarily fit ignition coil to crankcase.

Adjust air gap between ignition coil and flywheel using a thickness gauge and tighten bolts

**Ignition coil air gap : 0.3 - 0.5 mm**  
**(0.012 - 0.020 in.)**

**Tightening Torque : 6.9 - 8.8 N-m**  
**(70 - 90 kg-cm)**  
**(5.1 - 6.5 ft-lb.)**

Connect wiring from stop diode to the primary terminal of ignition coil.

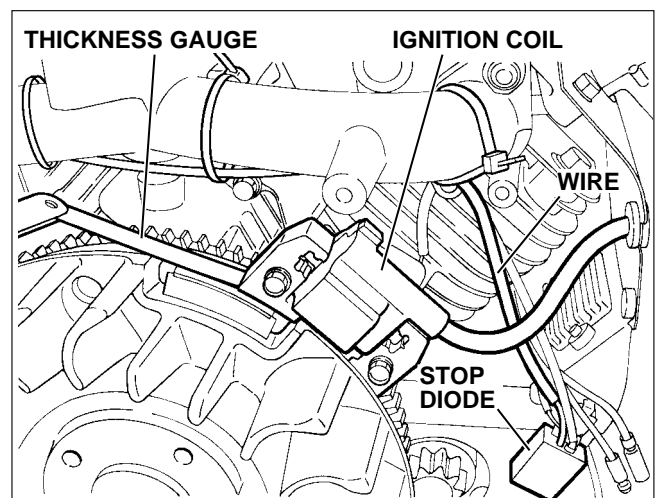

Fig. 5-43

## 20) CARBURETOR

Set gasket onto intake manifold and install carburetor.

**Tightening Torque : 16.7 - 18.6 N-m**  
**(170 - 190 kg-cm)**  
**(12.3 - 13.7 ft-lb.)**

## 21) GOVERNOR LEVER

Attach governor rod and rod spring between governor lever and carburetor throttle lever, and insert the governor lever to governor lever shaft. Tighten locking bolt temporarily.

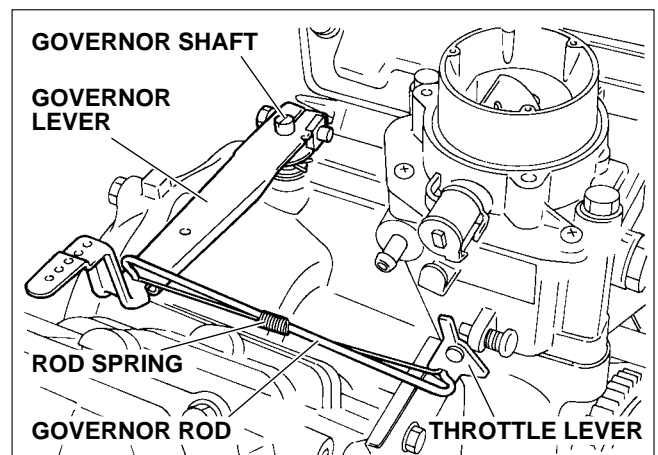

Fig. 5-44

## 22) SPEED CONTROL LEVER

- (1) Attach spring, friction washer, lock nut, etc. to speed control lever as shown in the illustration.
- (2) Attach governor spring between governor lever and speed control lever.

### Governor spring variation

		EH63, 64		EH65	
		50Hz	60Hz	50Hz	60Hz
<b>STD</b>	Part No.	263-42504-A3	263-42503-A3	263-42502-A3	263-42501-03
	Color	Red	Black	Silver	Yellow
	Hooking position	A - 3	A - 2	A - 3	A - 2
<b>RGV</b>	Part No.	263-42508-03	263-42507-03	263-42506-03	263-42505-03
	Color	Red line	Black line	White line	Yellow line
	Hooking position	A - 4	A - 4	A - 4	A - 4

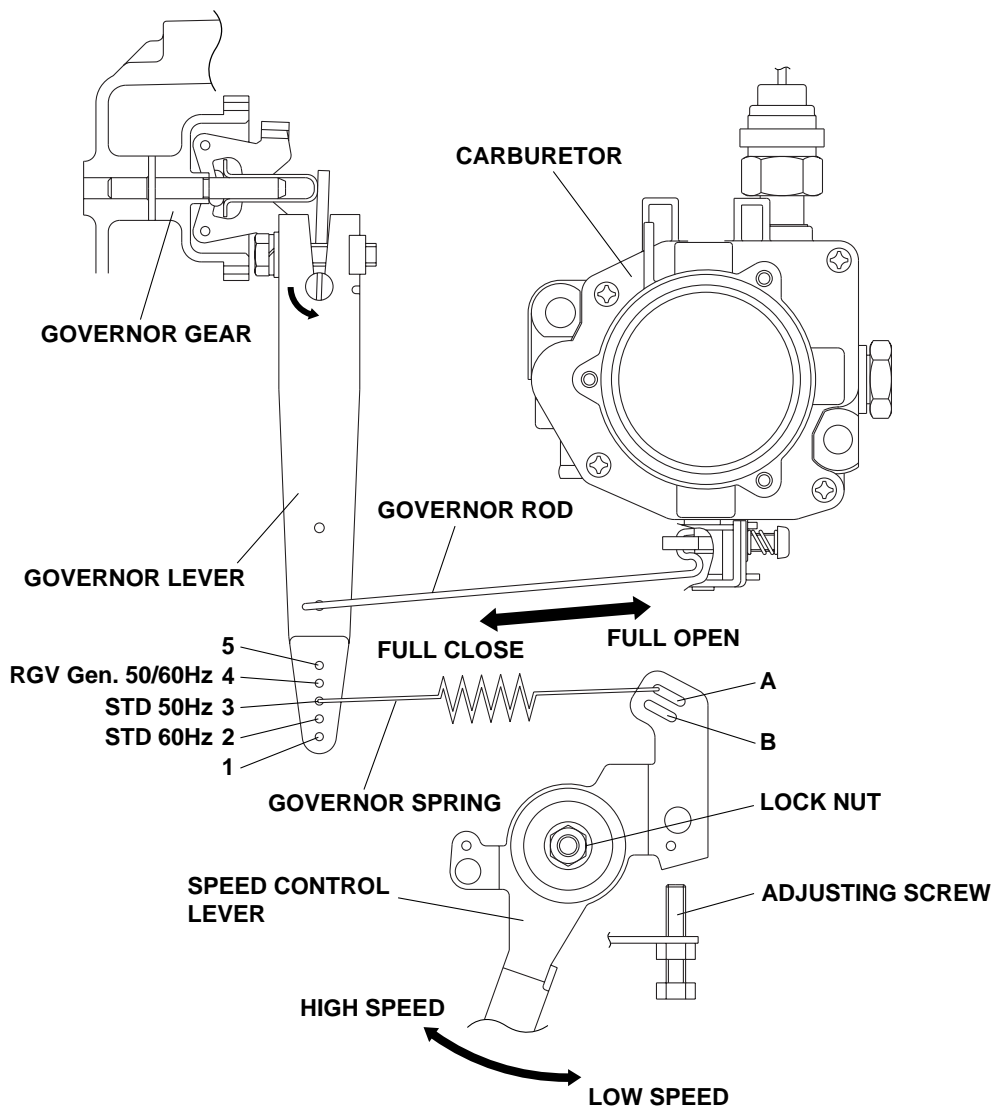

Fig. 5-45

- (3) Attach chock control link between carburetor chock lever and chock control lever.

### 23) ADJUST GOVERNOR SYSTEM

- (1) Push speed control lever all the way to the high speed position and fix it by tightening nut.
- (2) Check that governor lever is pulled by governor spring and carburetor throttle valve is fully open.
- (3) Turn governor shaft counterclockwise all the way and tighten lock bolt to secure the lever on the shaft.

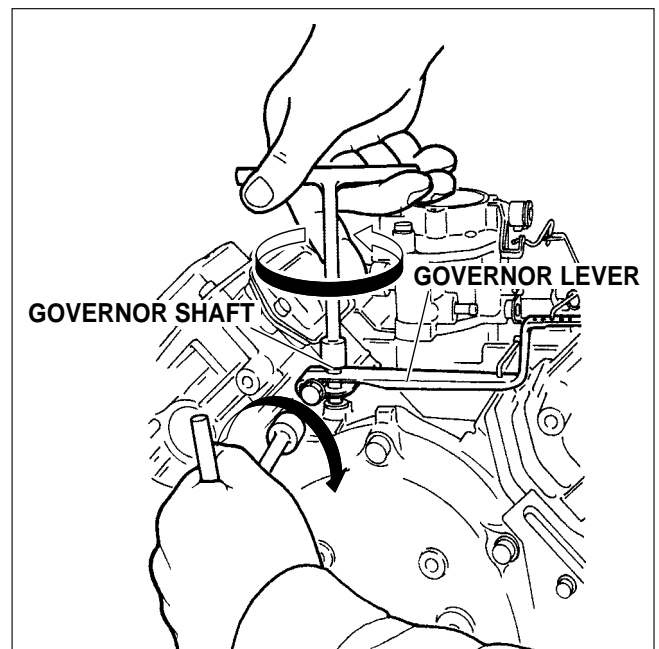

Fig. 5-46

### 24) BLOWER HOUSING

Attach blower housing to crankcase.

### 25) FUEL PUMP

Install fuel pump onto #2 cylinder baffle. Connect fuel pipe between carburetor and fuel pump.

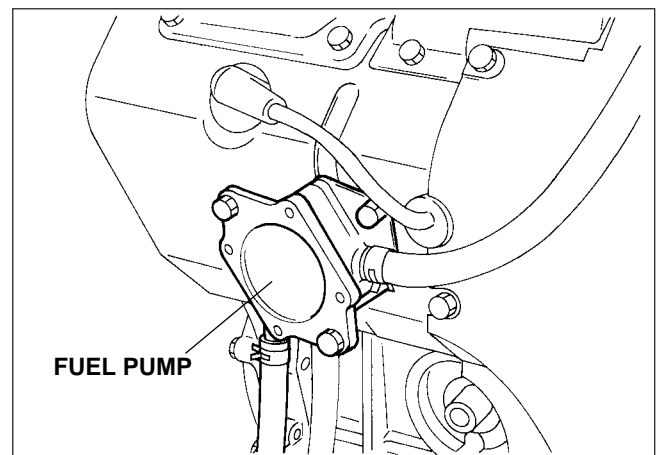

Fig. 5-47

### 26) AIR CLEANER

- (1) Connect breather pipe to air cleaner base.
- (2) Fit air cleaner base onto carburetor.
- (3) Connect breather pipe to #1 cylinder head.
- (4) Set air cleaner element along with urethane form onto base.
- (5) Install air cleaner cover with knob.

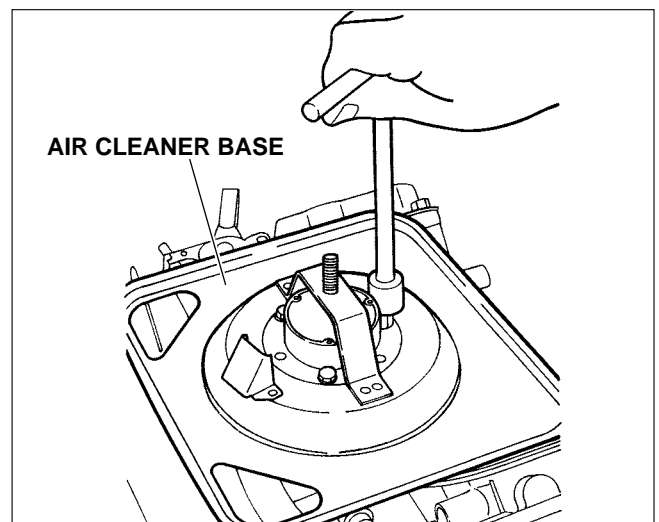

Fig. 5-48

## 27) OIL PRESSURE SWITCH

Install oil pressure switch onto crankcase.

**Tightening Torque : 5.9 - 9.8 N-m  
(60 - 100 kg-cm)  
(4.3 - 7.2 ft-lb.)**

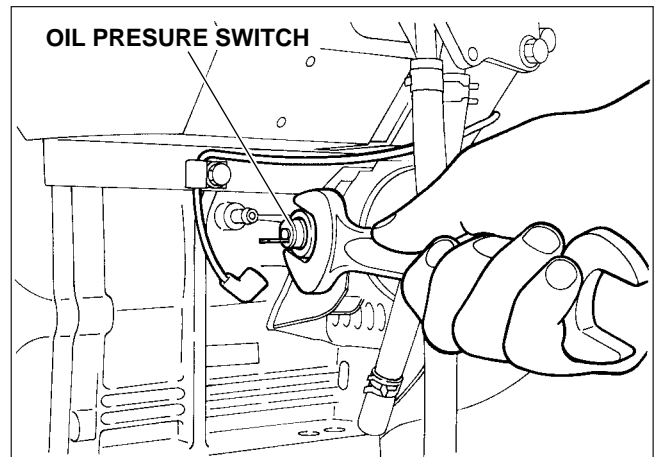

Fig. 5-49

## 28) OIL FILTER

Apply oil to O-ring and install oil filter by tightening about 3/4 turns after attaching crankcase surface.

**Tightening Torque : About 12.3 N-m  
(About 125 kg-cm)  
(About 9.0 ft-lb.)**

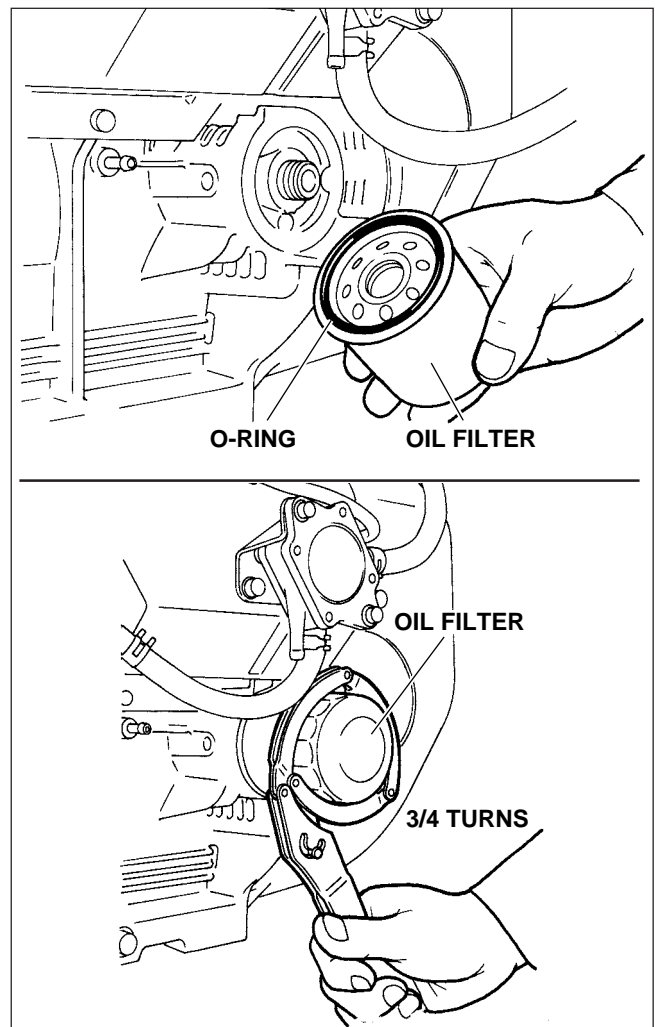

Fig. 5-50

## 29) FUEL PUMP PLUSE PIPE

Connect fuel pipe between fuel pump and crankcase nipple.

## 30) FINAL CHECK

Be sure to check loosen bolts and nuts, and also electric wiring connections.

31) Refill engine oil and start the engine. Engine oil will be lubricated oil passages and oil filter. Check the engine oil level and refill again to the upper level of oil level gauge.

**Note:**

- \* Total engine oil capacity is about 1.55 L.
- \* Use "SE" (API classification) or higher grade engine oil.

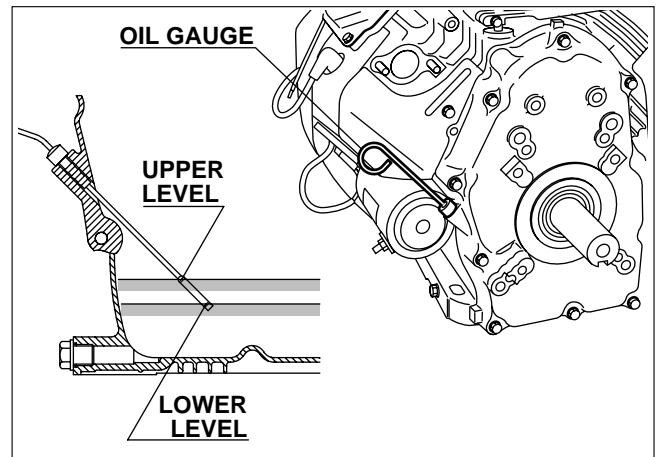

Fig. 5-51

### 5-5 BREAK-IN OPERATION

\* An engine that has been completely overhauled by being fitted with a new piston, rings, valves and connecting rod should be thoroughly RUN-IN before being put back into service. Good bearing surfaces and running clearances between the various parts can only be established by operating the engine under reduced speed and loads for a short period of time.

\* While the engine is being tested, check for oil leaks.

\* Make final carburetor adjustment and regulate the engine operating speed.

Step	Load			Engine Speed	Time
	EH63D	EH64D	EH65D		
Step 1	No Load			2,500 rpm	10 min.
Step 2	No Load			3,000 rpm	10 min.
Step 3	No Load			3,600 rpm	10 min.
Step 4	5.4 kW (7.3 HP)	6.0 kW (8 HP)	6.3 kW (8.5 HP)	3,600 rpm	30 min.
Step 5	10.8 kW (14.5 HP)	11.9 kW (16 HP)	12.7 kW (17 HP)	3,600 rpm	30 min.

Table. 5-1

# 6. MAGNETO

## 6-1 OPERATION AND FUNCTION

The ignition system is pointless flywheel magneto with automatic advancing characteristic.

Being different from the breaker point type ignition system, this system is completely free from such troubles as starting-up failure owing to dirty, burnt or corroded point surface.

The electronic automatic advancing ensures extremely easy starts and stable high performance at operating speed by advancing the ignition timing to the most suitable point.

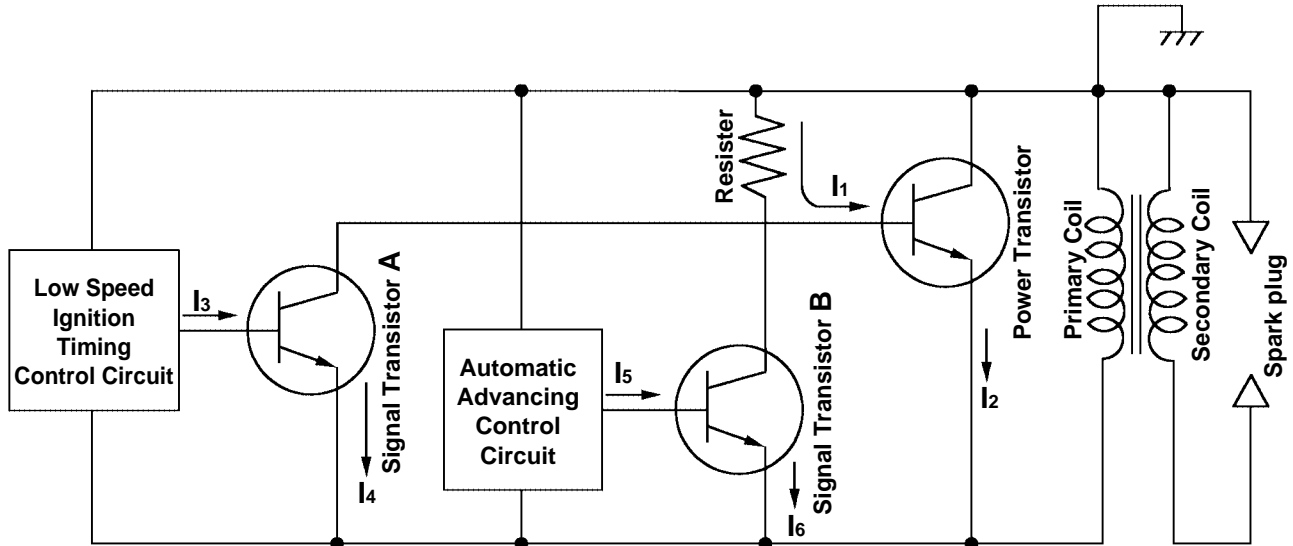

Fig. 6-1 (a)

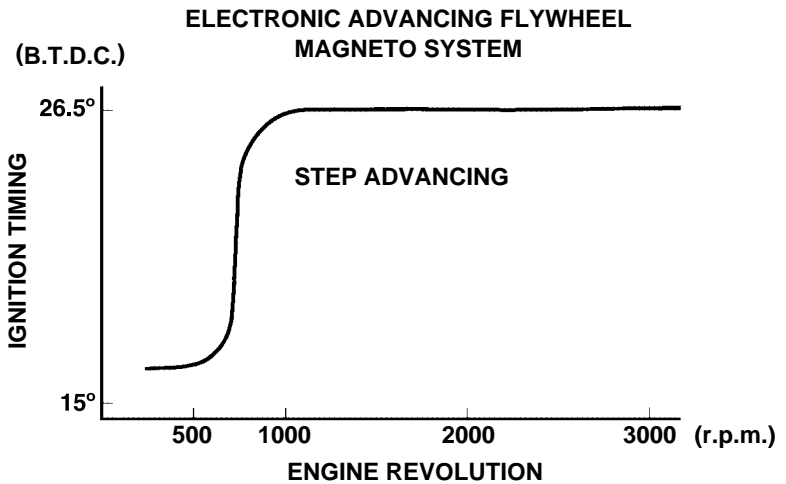

Fig. 6-1 (b)

### \* BASIC THEORY

- (1) Revolution of the flywheel generates electricity on the primary side of the ignition coil, and the base current  $I_1$  flows to the power transistor. Current  $I_1$  turns the power transistor "ON" and the electric current  $I_2$  flows.

(2) At lower engine revolution, when the flywheel reached the ignition point the low speed ignition timing control circuit operates to run the base current  $I_3$  to turn the signal transistor A "ON" allowing the current  $I_1$  to bypass as current  $I_4$ .

At this moment the power transistor turns "OFF" and the current  $I_2$  is abruptly shut resulting in the high voltage generated in the secondary coil which produces sparks at the spark plug.

(3) At higher engine revolution, the advancing control circuit operates at the ignition timing to run the base current  $I_5$  to turn the signal transistor B "ON" allowing the current  $I_1$  to bypass as current  $I_6$ .

At this moment the power transistor turns "OFF" and the current  $I_2$  is abruptly shut resulting in the high voltage generated in the secondary coil which produces sparks at the spark plug.

The operating timing of the advancing control circuit advances in accordance with the increase of engine speed resulting in the advancing of ignition timing.

**\* WIRING DIAGRAM**

Connect key switch, electric starter and battery with wirings of proper gauge as shown by the dotted lines in the wiring diagram.

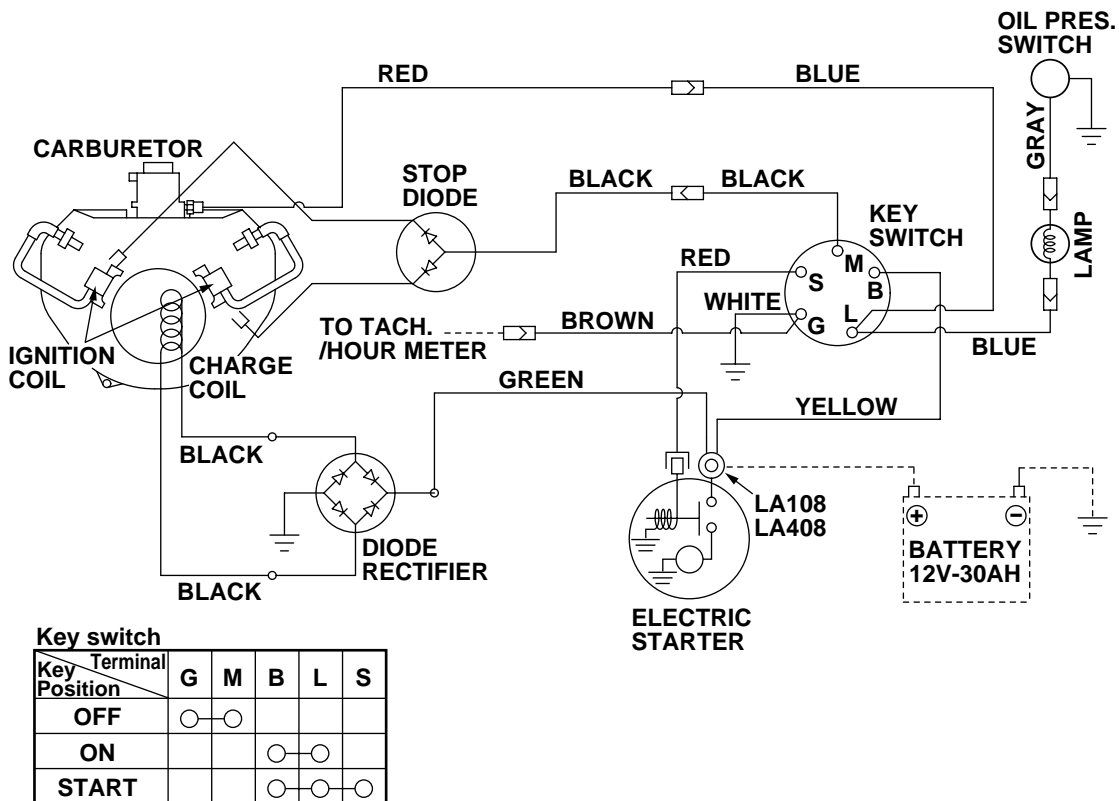

Fig. 6-2



# 7. LUBRICATION SYSTEM

## 7-1 OPERATION AND FUNCTION

- \* Full lubrication system is adopted, in combination with large-size trochoid oil pump and cartridge type oil filter.
- \* The large-size trochoid type oil pump is driven directly by crankshaft, and delivers pressurized engine oil to the journal and pin portions of crankshaft, camshaft etc.
- \* The engine oil in the oil pan is fed through the oil pump filter into oil pump and the engine oil pressure is adjusted by the relief valve after discharging from oil pump. Through the cartridge type oil filter, the engine oil is provided onto the rotating portions such as journal and pin portion of crankshaft and camshaft. The splashed engine oil is provided to the cylinder, piston, cylinder head valve system.
- \* The by-pass valve is incorporated into the cartridge type oil filter. In case that the oil filter element is clogged, the engine oil is fed through the by-pass valve into the crankcase oil passage.

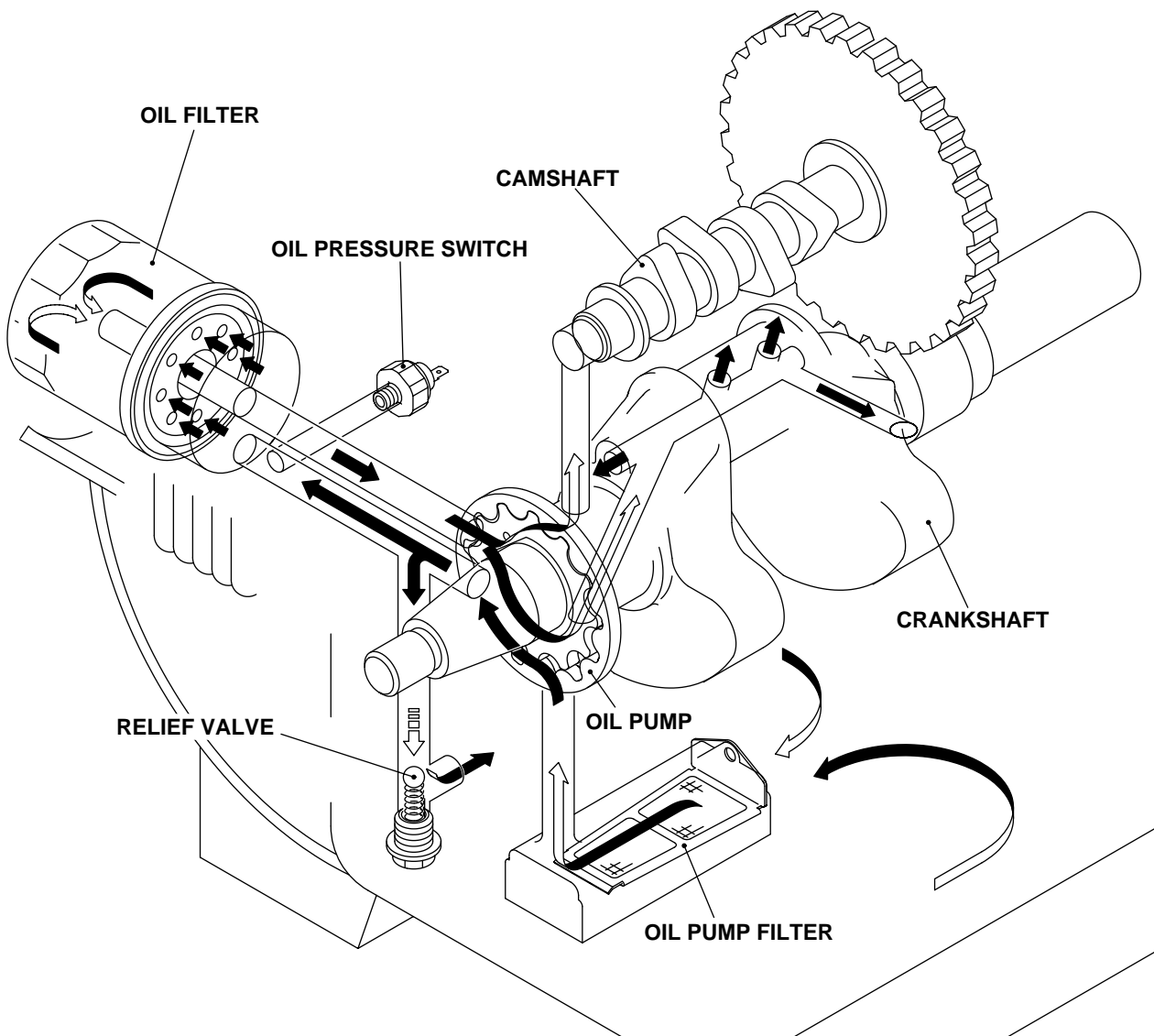

Fig. 7-1

# 8. CARBURETOR

## 8-1 OPERATION AND FUNCTION

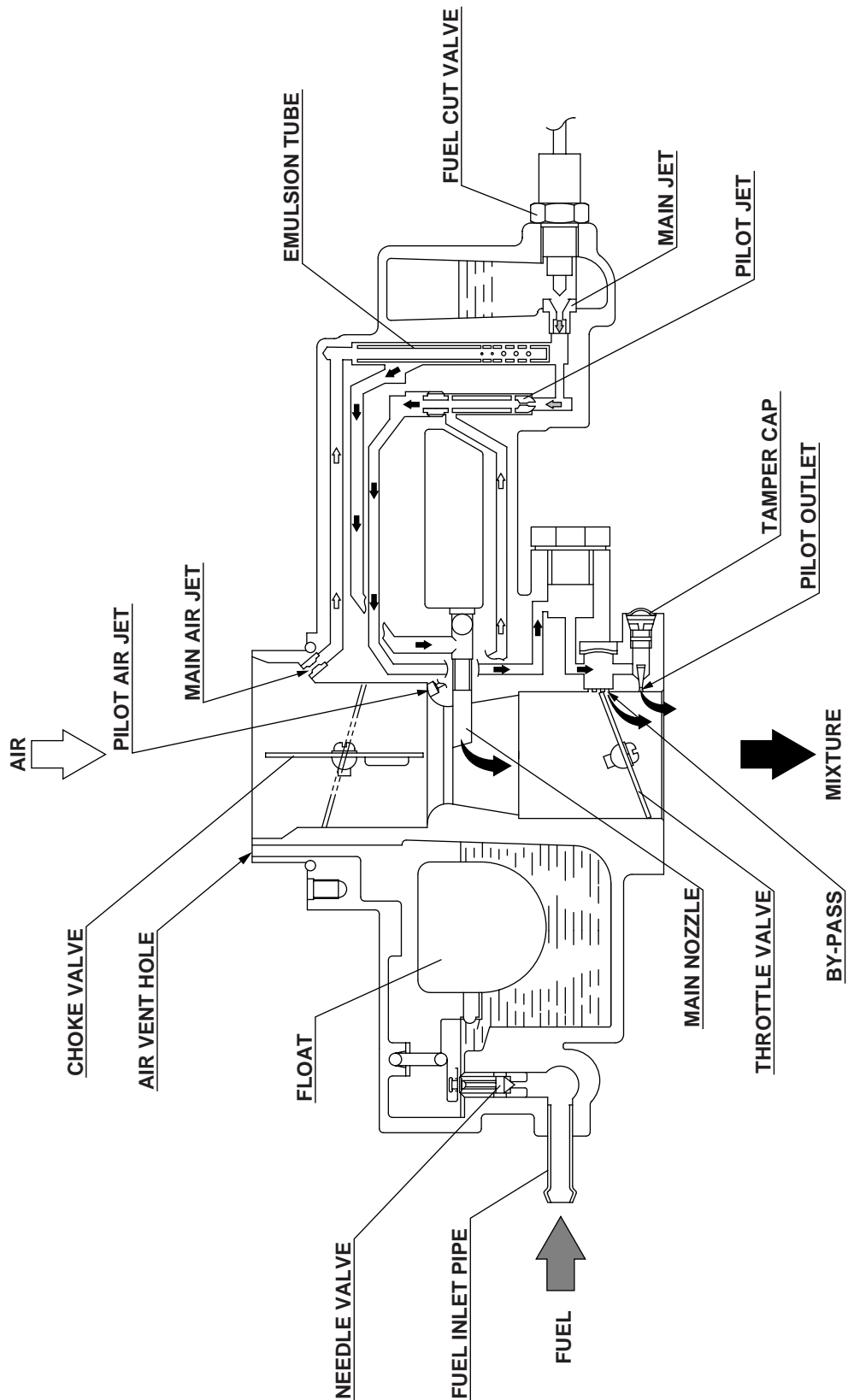

Fig. 8-1

### 8-1-1 FLOAT SYSTEM

The float system consists of a float and a needle valve, and maintains a constant fuel level during engine operation.

The fuel flows from the fuel tank into the float chamber through needle valve.

When the fuel rises to a specific level, the float rises, and when its buoyancy and fuel pressure are balanced, the needle valve closes to shut off the fuel, thereby keeping the fuel at the predetermined level.

Air vent hole of float chamber is provided around the carburetor air horn and the fuel vapor is sucked into the combustion chamber. This closed system has anti-dust feature.

### 8-1-2 PILOT SYSTEM

The pilot system feeds the fuel to the engine during idling and low-speed operation.

The fuel is fed through the main jet to the pilot jet, where it is metered, and mixed with the air metered by the pilot air jet.

The fuel-air mixture is fed to the engine through the pilot outlet and the by-pass.

At idling speed, the fuel is mainly fed from the pilot outlet.

### 8-1-3 MAIN SYSTEM

The main system feeds the fuel to the engine at medium-and high-speed operation.

The fuel is metered by the main jet and fed to the main nozzle. The air metered by the main air jet is mixed with the fuel through the emulsion tube, and the mixture is atomized out of the main bore. It is mixed again with the air taken through the air cleaner into an optimum fuel-air mixture, which is supplied to the engine.

### 8-1-4 CHOKE

The choke is used for easy start when engine is cold.

When the starter is operated with a choke valve fully closed, the negative pressure applied to the main nozzle increases and draws much fuel accordingly; thus easily start up the engine.

### 8-1-5 FUEL CUT VALVE

Fuel cut valve, operated with starter key switch, is equipped with main system of carburetor for preventing engine running on and after burning.

When the key switch is on, the valve is activated and the plunger is pulled in to open the main jet.

When the key switch is off, the power source to the valve is off. The plunger is pushed out by the return spring and stop the fuel flow of main jet.

## 8-2 COMPORNENT PARTS

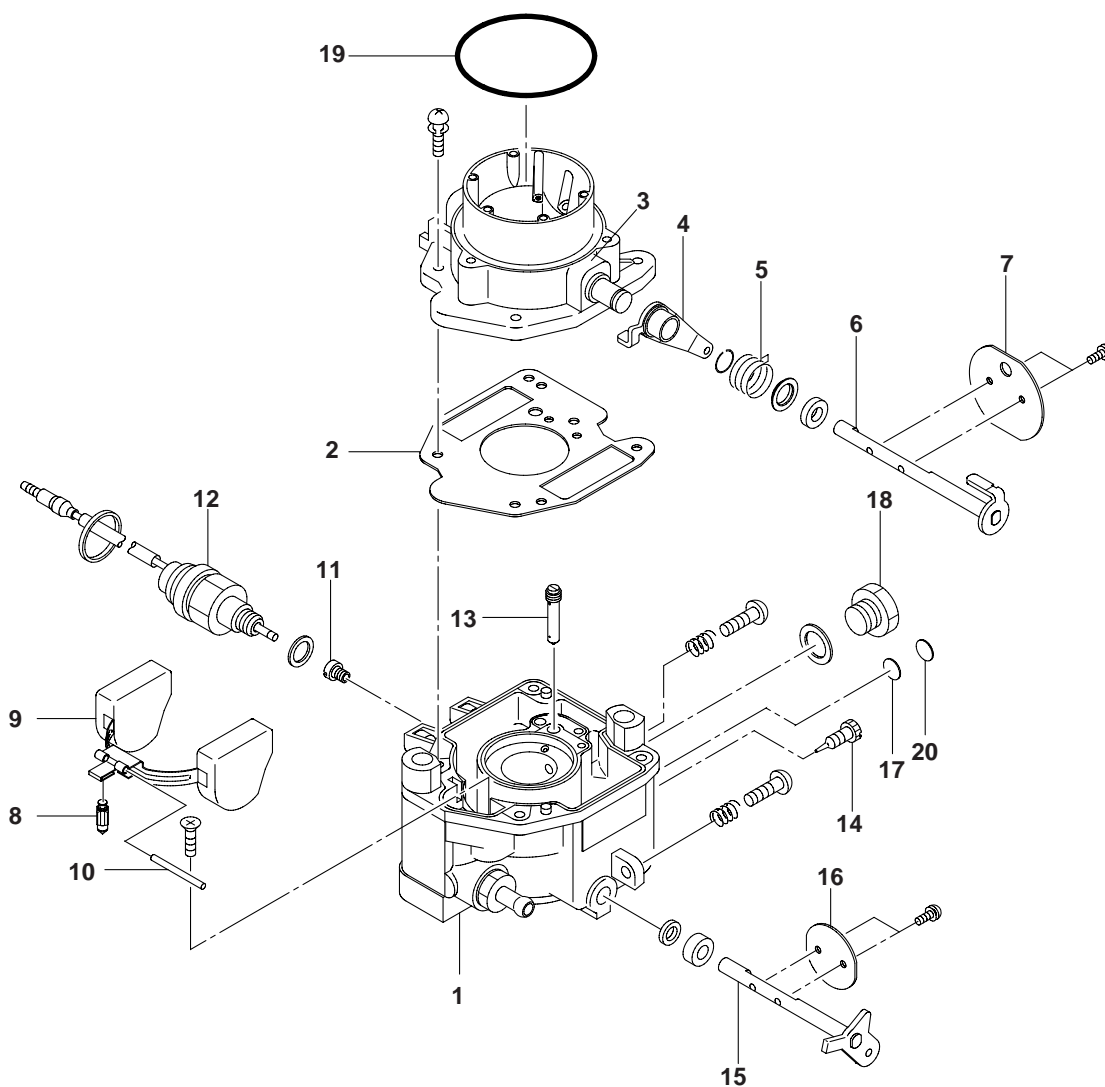

Fig. 8-2

- |                       |                          |
|-----------------------|--------------------------|
| 1. BODY, lower        | 11. MAIN JET             |
| 2. GASKET, body upper | 12. SOLENOID VALVE ASS'Y |
| 3. BODY, upper        | 13. JET, slow            |
| 4. LEVER ASSY, choke  | 14. NEEDLE, idle adjust  |
| 5. SPRING, choke      | 15. THROTTLE SHAFT ASS'Y |
| 6. SHAFT ASSY, choke  | 16. THROTTLE VALVE       |
| 7. CHOKE VALVE        | 17. EXPANSION PLUG       |
| 8. VALVE, float       | 18. PLUG                 |
| 9. FLOAT ASSY         | 19. O-RING               |
| 10. FLOAT PIN         | 20. PLUG, anti tamper    |

# 9. ELECTRIC STARTER

**NOTE ;**

For Electric starter operation, electric wiring should be connected among electric starter, magnetic switch, key switch and battery as shown in the diagram.

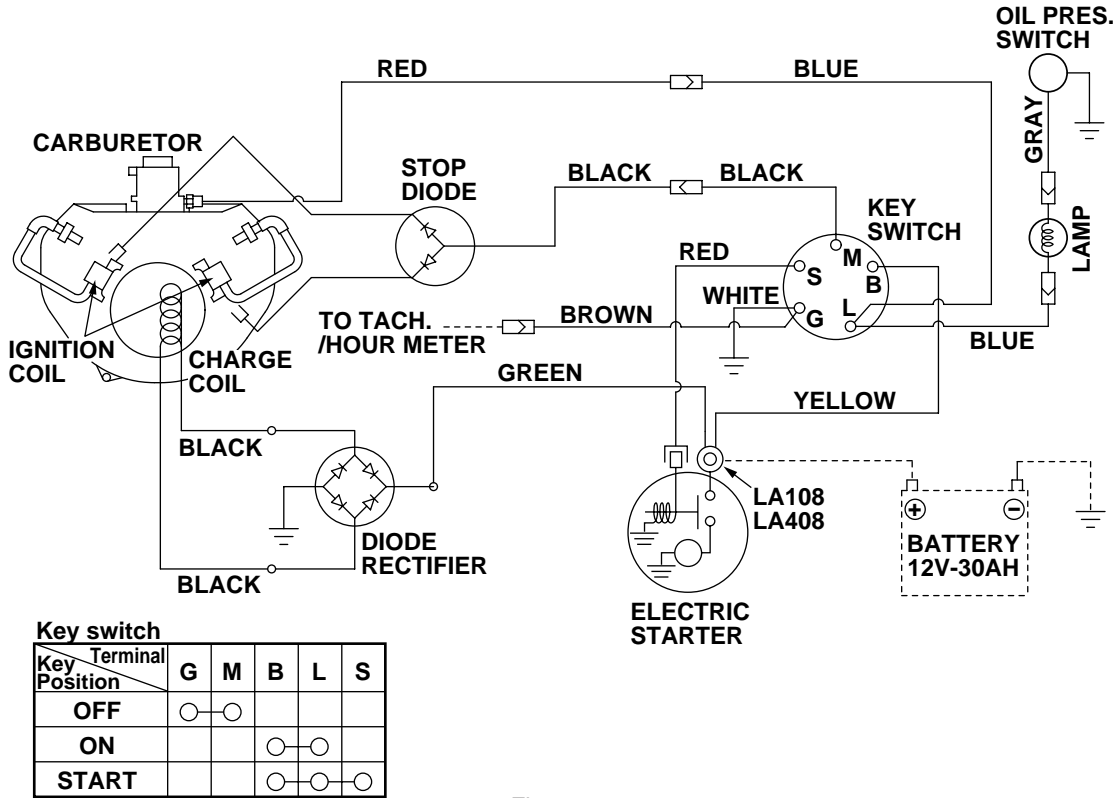

Fig. 9-1

## 9-1 OPERATION AND FUNCTION

When key switch is turned ON, lower electric current (M) flows through coil of magnetic switch and the coil is excited. The plunger is pulled and higher current (S) flows through electric starter.

When electric starter is operated, pinion gear is pushed out by the shift lever. The pinion gear is engaged with ring gear and flywheel and crankshaft are rotated.

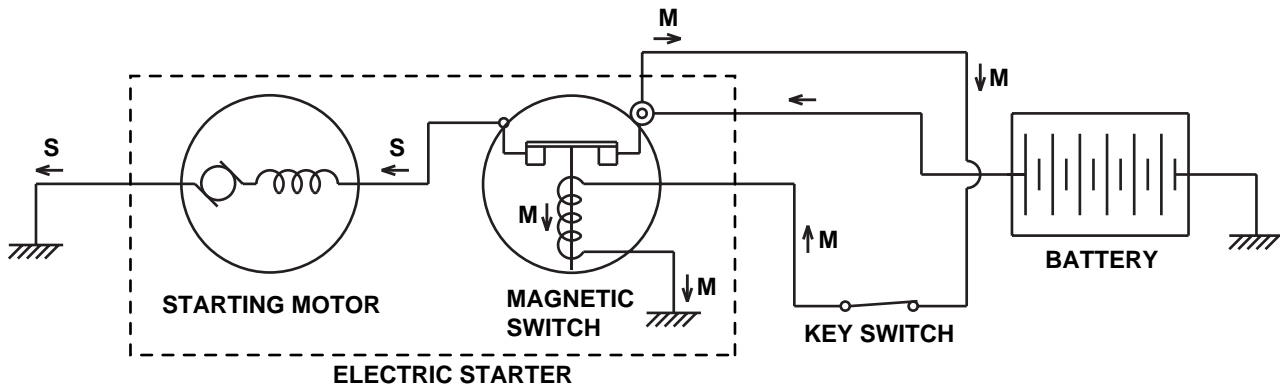

Fig. 9-2

## 9-2 COMPONENT PARTS

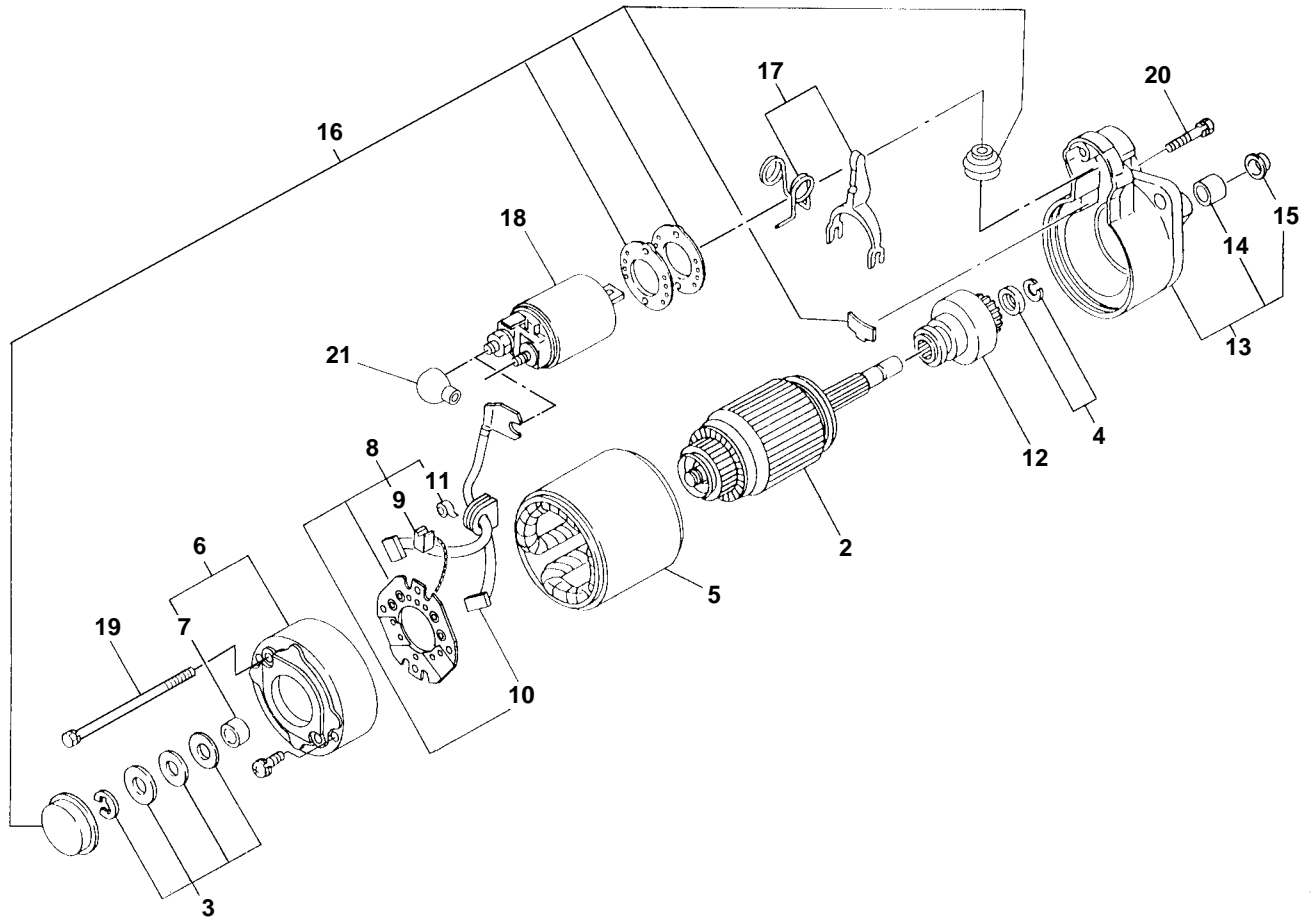

Fig. 9-3

- |                         |                           |
|-------------------------|---------------------------|
| 1. Starting motor Ass'y | 15. Gear case metal cover |
| 2. Armature Ass'y       | 16. Dust cover kit        |
| 3. Thrust washer kit    | 17. Shift lever kit       |
| 4. Pinion stopper set   | 18. Magnetic switch Ass'y |
| 5. Yoke Ass'y           | 19. Through bolt          |
| 6. Rear cover Ass'y     | 20. Bolt                  |
| 7. Starter metal        | 21. M terminal cover      |
| 8. Brush holder Ass'y   |                           |
| 9. Brush (-)            |                           |
| 10. Brush set           |                           |
| 11. Brush spring        |                           |
| 12. Pinion Ass'y        |                           |
| 13. Gear case Ass'y     |                           |
| 14. Starter metal       |                           |

## 10. TROUBLESHOOTING

The following three conditions must be fulfilled for satisfactory engine start.

- (1) The cylinder filled with a proper fuel-air mixture.
- (2) Good compression in the cylinder.
- (3) Good spark, properly timed, to ignite the mixture.

The engine cannot be started unless these three conditions are met.

There are also other factors which make engine start difficult, e.g., a heavy load on the engine when it is about to start at low speed, and a high back pressure due to a long exhaust pipe.

The most common causes of engine troubles are given below:

### 10-1 NO ENGINE OPERATION

Phenomenon	Possible causes	Remedy
1. Electric starter does not operate.	1) Poor connection of key switch wiring	Check, repair or replace
	2) Wiring discontinuity between key switch and starter motor	Replace
	3) Wiring discontinuity between battery and starter motor	Replace
	4) Improper battery (low capacity) or discharged battery	Charge or replace battery
	5) Poor connection of battery terminal	Check, clean or replace
	6) Starter magnetic switch faulty	Check, clean, repair or replace
	7) Starter motor faulty	Repair or replace
	8) Crankshaft seizure	Check, repair or replace
	9) Seizure between piston and cylinder	Check, repair or replace
2. Electric starter operates, but engine does not start.	1) No fuel	Refill
	2) Poor connection or discontinuity of ignition system wirings	Check, repair or replace
	3) Electric starter faulty	Repair or replace

## 10-2 STARTING DIFFICULTIES

Phenomenon	Possible causes	Remedy
1. Low engine speed at starting	1) Battery discharged	Charge battery
	2) Poor connection between battery and starter motor	Clean or repair
	3) Poor connection between battery and ground	Clean or repair
	4) Electric starter faulty	Repair or replace
	5) Improper engine oil	Replace with recommended engine oil
2. Ignition system malfunction	Spark plug * Improper spark plug gap * No insulation * Carbon deposits	Adjust Replace Clean
	Ignition coil * No insulation or discontinuity * Poor connection or discontinuity of ignition code	Replace Repair or replace
	Improper air gap between ignition coil and flywheel	Adjust
3. Fuel system malfunction	1) No fuel in fuel tank	Refill
	2) Fuel pump clogged	Clean
	3) Fuel hose clogged or pinched	Clean or replace
	4) Air mixing into fuel lines	Check and adjust connecting portion
	5) Improper gasoline or water infiltration	Replace
	6) Carburetor * Overflow * Clogged or damaged * Improper operation of throttle valve	Adjust Disassembly and clean Check and adjust
	7) Poor connection of fuel cut valve wiring	Check and repair
4. Engine core components malfunction	1) Insufficient tightening of cylinder head bolts	Check and retighten
	2) Wear of piston, piston ring and/or cylinder	Repair or replace
	3) Improper contact of valve and seat	Repair
	4) Valve seizure	Repair
	5) Improper valve clearance	Adjust
	6) Intake manifold gasket leakage	Retighten intake manifold bolts or replace gasket
	7) Carburetor gasket leakage	Retighten carburetor bolts or replace gasket
	8) Insufficient tightening of spark plug	Retighten



### 10-3. INSUFFICIENT OUTPUT

Phenomenon	Possible causes	Remedy
1. Low compression	1) Loosen spark plug	Retighten or replace gasket
	2) Cylinder head gasket leakage	Retighten or replace gasket
	3) Piston ring(s) seizure or wear	Replace
	4) Piston or cylinder wear	Repair or replace
	5) Incorrect valve and seat contact	Repair or replace
	6) Valve stem seizure	Repair or replace
	7) Improper valve clearance	Adjust
2. Ignition system malfunction	1) Spark plug faulty	Replace
	2) Ignition coil faulty	Replace
	3) Improper air gap between ignition coil and flywheel	Adjust
	4) Magneto demagnetization	Replace
3. Fuel system malfunction	1) Carburetor clogged	Disassembly and clean
	2) Improper fuel pump operation	Disassembly and clean
	3) Fuel strainer or fuel hose clogged	Clean or replace
	4) Air mixing into fuel lines	Check and adjust connecting portion
	5) Improper gasoline or water infiltration	Replace
4. Low intake air volume	1) Air cleaner clogged	Clean or replace
	2) Throttle valve faulty	Repair or replace

### 10-4. OVERHEAT

Phenomenon	Possible causes	Remedy
Overheating	1) Cooling air flow obstructed at inlet or cylinder baffle portion	Clean
	2) Improper engine oil	Replace
	3) Lean air/fuel mixture	Check and adjust carburetor
	4) Excessive back pressure of exhaust system	Check, clean or replace
	5) Over-load	Change to rated load

## 10-5. ROUGH IDLING

Phenomenon	Possible causes	Remedy
1. Carburetor	1) Low idling speed	Adjust
	2) Carburetor slow system passage clogged	Check and clean
2. Intake system	1) Air mixing from connecting portion of air intake system	Check , tighten or replace gasket
3. Cylinder head	1) Cylinder head gasket faulty (blow-by)	Replace
4. Valve system	1) Improper valve clearance	Adjust
	2) Leakage from valve seat	Adjust valve seat contact
	3) Excessive clearance between valve stem and guide	Replace
5. Ignition system	1) Weak ignition spark	Check and replace spark plug

## 10-6. HIGH ENGINE OIL CONSUMPTION

Phenomenon	Possible causes	Remedy
1. Oil leakage	1) Loosen drain plug	Tighten
	2) Drain plug gasket damaged	Replace
	3) Incorrect oil filter fitting	Repair
	4) Loosen main bearing cover bolts	Tighten
	5) Main bearing cover gasket damaged	Replace
	6) Crankshaft oil seal damaged	Replace
2. Oil dilution	1) Piston oil ring faulty	Replace
	2) Piston rings seizure, wear or poor contact	Replace
	3) Excessive wear of piston and cylinder	Replace
	4) Excessive wear of valve stem	Replace
	5) High oil level	Adjust oil level
	6) Breather faulty	Repair or replace

## 10-7. HIGH FUEL CONSUMPTION

Phenomenon	Possible causes	Remedy
1. Fuel system	1) Over-size main jet	Replace
	2) Needle valve faulty and/or high fuel level in float chamber	Adjust or replace
	3) Chock valve does not open fully.	Repair or replace
2. Engine core components	1) Low compression	Check or repair
	2) Over cooling	Check and adjust load and/or engine speed

## 10-8. DETONATION

Phenomenon	Possible causes	Remedy
1. Ignition system malfunction	1) Poor connection of ignition system wirings	Check and connect properly
	2) Improper or damaged spark plug	Clean or replace
2. Fuel system malfunction	1) Lean or rich air/fuel mixture	Clean, adjust or replace
	2) Carburetor damaged	Disassembly and clean
	3) Fuel lines clogged or damaged	Clean or replace
	4) Air mixing from connecting portion of air intake system	Connect properly or replace gasket
3. Cylinder head	1) Carbon deposit in combustion chamber	Remove and clean
	2) Cylinder head gasket faulty (blow-by)	Replace
4. Valve system	1) Improper valve clearance	Adjust
	2) Valve heat deterioration	Replace
	3) Valve spring deterioration	Replace
	4) Improper valve timing	Adjust

## 10-9. ENGINE MISFIRE

Phenomenon	Possible causes	Remedy
1. Ignition system	1) Imprpper spark plug gap or damaged electrode	Clean, adjust or replace
	2) ignition coil faulty	Replace
	3) Damaged ignition system wirings	Replace
	4) Poor connection of ignition system wirings	Check and connect properly
2. Fuel system	1) Lean or rich air/fuel mixture	Disassembly and repair
	2) Carburetor clogged	Disassembly and repair
	3) Improper idling adjustment of carburetor	Adjust
	4) Improper gasoline or water infiltration	Replace
3. Engine core components	1) Valve heat deterioration or improper valve adjustment	Adjust or replace
	2) Valve spring deterioration	Replace
	3) Low compression	Check, adjust or replace

# 11. INSTALLATION

Engine life, ease of maintenance and inspection, frequency of checks and repairs, and operating cost all depend on the way in which the engine is installed. Review the following instructions carefully for installing the engine.

## 11-1 INSTALLING

When mounting the engine, carefully examine its position, the method of connecting it to a machine, the foundation, and the method of supporting the engine.

When determining its mounting position, in particular, make sure that gasoline and oil can easily be supplied and checked, the spark plug can easily be checked, the air cleaner can easily be serviced, and that the oil can easily be discharged.

## 11-2 VENTILATION

Fresh air is necessary for cooling the engine and burning the fuel.

In the case the engine is operated under a hood or in a small room, temperature rise in the engine room can cause vapor lock, oil deterioration, increased oil consumption, loss of power, piston seizure, shorter engine life, etc., making it impossible to operate the engine properly. It is necessary, therefore, to provide a duct or baffle to guide cooling air to the engine to prevent recirculation of the hot air used for engine cooling, and temperature rise of the machine.

Keep the engine room temperature below 50 °C even in the hottest period of the year.

## 11-3 EXHAUST GAS DISCHARGE

Exhaust gas is noxious. When operating the engine indoors, be sure to discharge the exhaust gas outdoors. If a long exhaust pipe is used in such a case, the internal resistance increases causing loss of engine power. Thus pipe inside diameter must be increased in proportion to exhaust pipe length.

Exhaust pipe :      Less than 3 m long --- pipe inside diameter 30 mm  
                                 Less than 5m long --- pipe inside diameter 33 mm.

## 11-4 POWER TRANSMISSION TO DRIVEN MACHINES

### 11-4-1 BELT DRIVE

Take the following notes into consideration.

- \* V-belts are preferable to flat belts.
- \* The driving shaft of the engine must be parallel to the driven shaft of the machine.
- \* The driving pulley of the engine must be in line with the driven pulley of the machine.
- \* Install the engine pulley as close to the engine as possible.
- \* If possible, span the belt horizontally.
- \* Disengage the load when starting the engine.

If no clutch is used, use a belt tension pulley or the like.

### 11-4-2 FLEXIBLE COUPLING

When using a flexible coupling, run out and misalignment between the driven shaft and engine shaft must be minimized. Run out and misalignment tolerance are specified by the coupling manufacturer.

# 12. SERVICE DATA

## 12-1 CLEARANCE DATA AND LIMITS

Unit : mm (in)

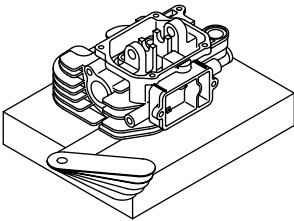
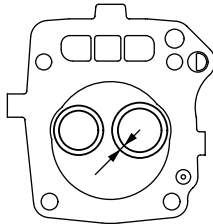
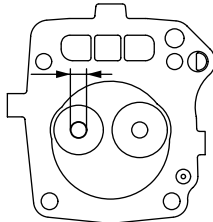
ITEM	EH63D/ 64D / 65D		
	STD	Limit	
CYLINDER HEAD * Flatness 		0.05 or less (0.002 or less)	0.1 (0.004)
* Valve seat contact width 	IN. EX.	0.7 - 1.0 (0.028 - 0.039)	2.0 (0.079)
* Valve guide inside dia. 		6.035 - 6.053 (0.2376 - 0.2383)	6.15 (0.242)

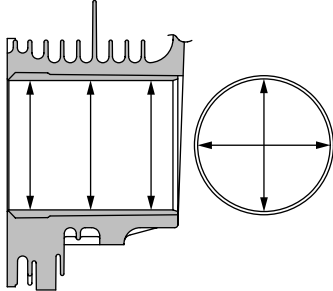
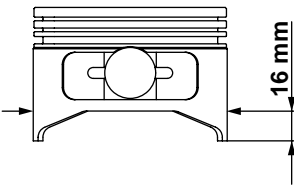
ITEM		EH63D/ 64D / 65D	
		STD	Limit
CYLINDER * Inside dia. 	STD	80.000 - 80.019 (3.1496 - 3.1504)	To be rebored when the difference between max. and min. of diameter reached to 0.1 (0.004).
	1 st reboring	80.250 - 80.269 (3.159 - 3.160)	Ditto
	2 st reboring	80.500 - 80.519 (3.169 - 3.170)	—
		0.01 (0.004)	—
		0.015 (0.0006)	—
* Roundness after reboring.  * Cylindricity after reboring.			
PISTON * Piston size (At skirt in thrust direction) 	STD	79.968 - 79.988 (3.148 - 3.149)	79.878 (3.145)
	1 st o / s	80.218 - 80.238 (3.158 - 3.159)	80.128 (3.155)
	2nd o / s	80.468 - 80.488 (3.168 - 3.169)	80.378 (3.164)

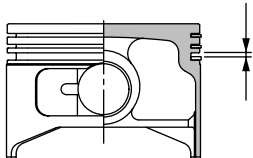
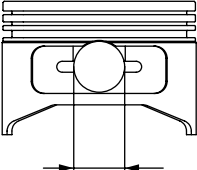
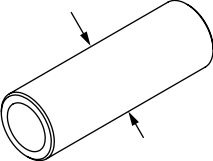
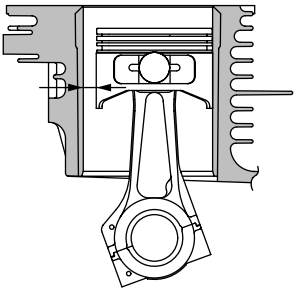
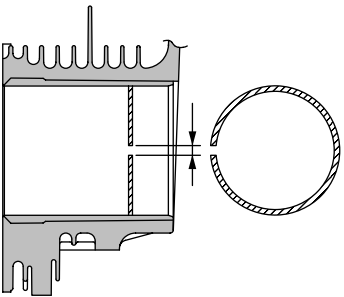
ITEM	EH63D/ 64D / 65D		
	STD	Limit	
<b>PISTON</b> * Ring groove side clearance  * Piston pin hole  * Piston pin outside dia.  * Clearance between piston and cylinder at skirt area.  * Piston ring end gap 	Top	0.05 - 0.09 (0.0002 - 0.0035)	0.15 (0.006)
	2nd	0.03 - 0.07 (0.0012 - 0.0028)	0.15 (0.006)
	Oil ring	0.057- 0.175 (0.0022 - 0.0069)	0.15 (0.006)
		20.989 - 21.002 (0.8263 - 0.8269)	21.035 (0.8281)
		20.991 - 21.000 (0.8264 - 0.8268)	20.960 (0.8251)
		0.012 - 0.051 (0.0005 - 0.0020)	0.25 (0.0098)
	Top 2nd	0.2 - 0.4 (0.0079 - 0.0157)	1.5 (0.0591)
	Oil ring	0.2 - 0.7 (0.0079 - 0.0276)	1.5 (0.0591)

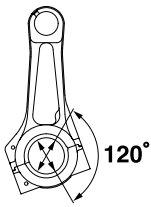
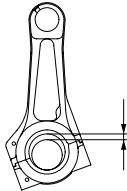
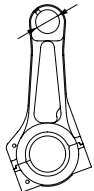
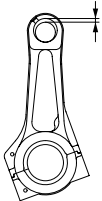
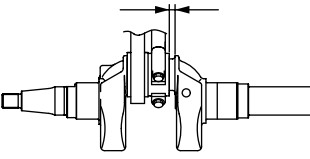
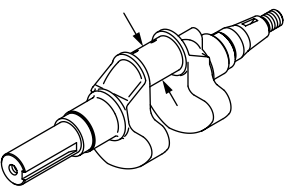
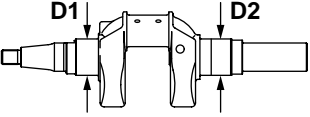

ITEM	EH63D/ 64D / 65D	
	STD	Limit
<p>CONNECTING ROD</p> <p>* Big end inside dia.</p> 	<p>39.000 - 39.016 (1.5354 - 1.5361)</p>	<p>39.100 (1.5394)</p>
<p>* Clearance between big end and crankpin</p> 	<p>0.030 - 0.060 (0.0012 - 0.0024)</p>	<p>0.2 (0.0079)</p>
<p>* Small end inside dia.</p> 	<p>21.010 - 21.023 (0.8272 - 0.8277)</p>	<p>21.080 (0.8299)</p>
<p>* Clearance between small end and piston pin</p> 	<p>0.010 - 0.032 (0.0004 - 0.0013)</p>	<p>0.12 (0.0047)</p>
<p>* Big end side clearance</p> 	<p>0.1 - 0.4 (0.0039 - 0.0157)</p>	<p>1.0 (0.0394)</p>
<p>CRANKSHAFT</p> <p>* Crankpin outside dia.</p> 	<p>38.956 - 38.970 (1.5337 - 1.5343)</p>	<p>38.90 (1.5315)</p>
<p>* Journal dia.</p> 	<p>D1 : 44.984 - 45.000 (1.77102 - 1.77165)</p> <p>D2 : 44.986 - 44.997 (1.77110 - 1.77154)</p>	<p>—————</p>

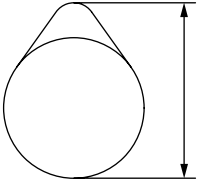
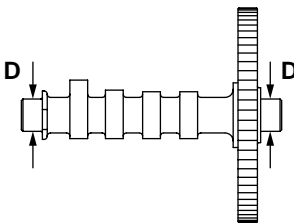
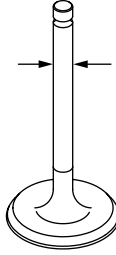
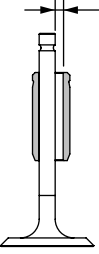
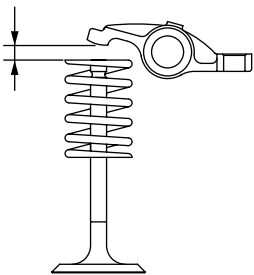
ITEM	EH63D/ 64D / 65D	
	STD	Limit
<p>CAMSHAFT</p> <p>* Cam height (IN. and EX.)</p> 		<p>36.1 - 36.3 (1.4213 - 1.4291)</p> <p>35.95 (1.4154)</p>
<p>* Journal outside dia. "D" type</p> 		<p>19.967 - 19.980 (0.7861 - 0.7866)</p> <p>19.950 (0.7854)</p>
<p>VALVE</p> <p>* Valve stem outside dia.</p>  <p>*Clearance between valve stem dia. and valve guide.</p>  <p>* Valve clearance</p> 	IN.	<p>5.970 - 5.985 (0.2350 - 0.2356)</p> <p>5.85 (0.2303)</p>
	EX.	<p>5.960 - 5.975 (0.2346 - 0.2352)</p> <p>5.85 (0.2303)</p>
	IN.	<p>0.050 - 0.083 (0.0022 - 0.0033)</p> <p>0.30 (0.0118)</p>
	EX.	<p>0.060 - 0.093 (0.0024 - 0.0037)</p> <p>0.30 (0.0118)</p>
	IN. / EX. (cold)	<p>0.085 - 0.115 (0.0034 - 0.0045)</p>

Unit : mm (in)

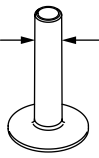
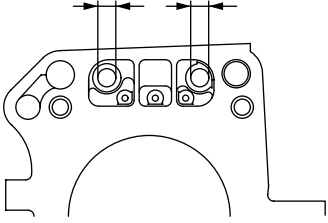
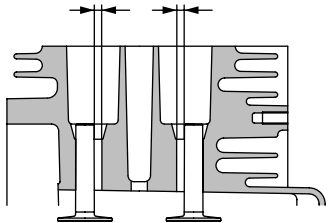
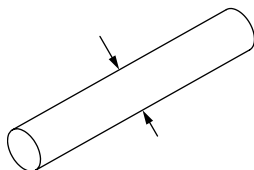
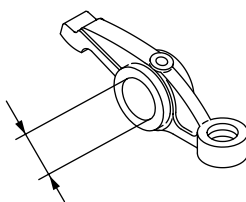
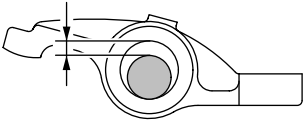
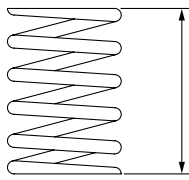
ITEM	EH63D/ 64D / 65D	
	STD	Limit
<p>TAPPET</p> <p>* Stem outside dia.</p> 	<p>8.960 - 8.975 (0.3528 - 0.3533)</p>	<p>8.93 (0.3516)</p>
<p>* Guide inside dia.</p> 	<p>9.00 - 9.015 (0.3543 - 0.3549)</p>	<p>9.08 (0.3575)</p>
<p>* Tappet guide clearance</p> 	<p>0.025 - 0.055 (0.0010 - 0.0022)</p>	<p>0.15 (0.0059)</p>
<p>ROCKER ARM</p> <p>* Rocker shaft outside dia.</p> 	<p>11.986 - 11.994 (0.4719 - 0.4722)</p>	<p>11.92 (0.4693)</p>
<p>* Rocker arm hole dia.</p> 	<p>12.006 - 12.024 (0.4727 - 0.4734)</p>	<p>12.07 (0.4752)</p>
<p>* Rocker arm shaft clearance</p> 	<p>0.012 - 0.038 (0.0005 - 0.0015)</p>	<p>0.15 (0.0059)</p>
<p>VALVE SPRING FREE LENGTH</p> 	<p>39.5 (1.5551)</p>	<p>—</p>

Unit : mm (in)

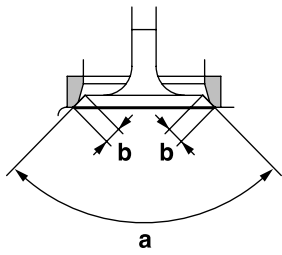
ITEM	EH63D / 64D / 65D		
	STD	Limit	
VALVE SEAT ANGLE (IN. EX.) * Valve cutter angle (a) * Valve contact width (b)	 <p>The diagram shows a cross-section of a valve seat. A curved line labeled 'a' indicates the valve cutter angle. Two arrows labeled 'b' indicate the valve contact width on either side of the seat.</p>	a : 90° b : 0.7 - 1.0 (0.028 - 0.039)	2.0 (0.079)

## 12-2 TORQUE SPECIFICATIONS

ITEMS		Tightening Torque		
		N·m	Kg-cm	ft-lb.
Breather cover		2.9 - 4.9	30 - 50	2.2 - 3.6
Breather cover		16.7 - 18.6	170 - 190	12.3 - 13.7
Carburetor bolts		3.1 - 4.1	30 - 40	2.2 - 2.9
Connecting rod cap bolts		22.1 - 27.0	225 - 275	16.3 - 19.9
Cylinder head bolts		33.3 - 41.2	340 - 420	24.6 - 30.4
Flywheel nut		83.3 - 93.1	850 - 950	61.5 - 68.7
Ignition coil		6.9 - 8.8	70 - 90	5.1 - 6.5
Intake manifold bolts		16.7 - 18.6	170 - 190	12.3 - 13.7
Main bearing cover bolts	7T Bolt	16.7 - 18.6	170 - 190	12.3 - 13.7
	9T Bolt	22.5 - 27.5	230 - 280	16.6 - 20.2
Oil filter		12.3	100 - 150	9
Oil pressure switch		5.9 - 9.8	60 - 100	4.3 - 7.2
Oil relief plug		11.8 - 14.7	150 - 250	10.9 - 18.1
Rocker arm nut		9.8 - 13.7	100 - 140	7.2 - 10.1
Rocker cover		2.9 - 4.9	30 - 50	2.2 - 3.6
Spark plug	New one	11.8 - 14.7	120 - 150	8.7 - 10.9
	Current one	22.5 - 26.5	225 - 275	16.6 - 19.5
Starter motor bolts		16.7 - 18.6	170 - 190	12.3 - 13.7

### 12-3 OIL GRADE CHART

Use oil classified as SE or higher.

Multi-grade oil tends to increase its consumption at high ambient temperature.

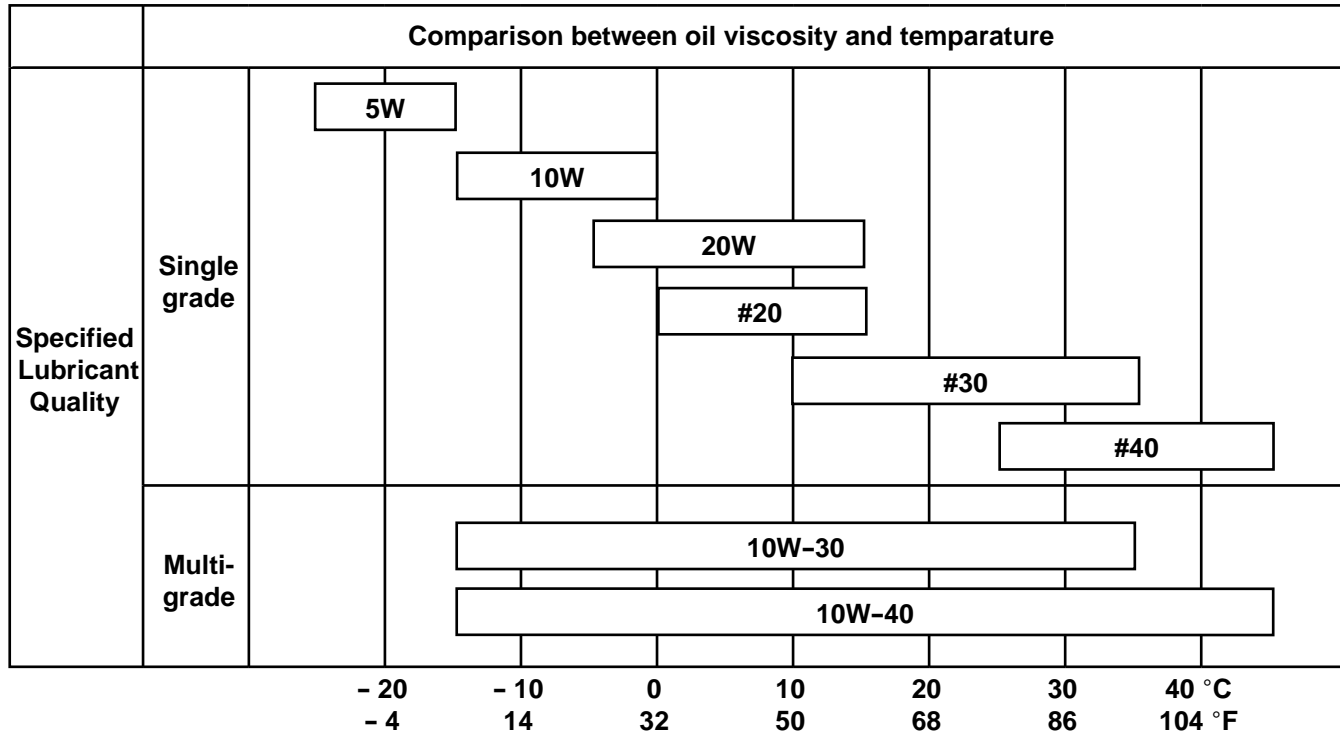

# 13. MAINTENANCE AND STORAGE

## 13-1 DAILY MAINTENANCE

Every day before operating engine, check the following items;

MAINTENANCE ITEMS	REMARKS
1) Clean away dust and chaff from engine.	Governor linkage is especially sensitive to dust.
2) Check fuel leakage from fuel system. If any, retighten fasteners or replace necessary parts.	
3) Inspect for loose hardware and retighten if necessary.	Loose bolts and nuts may come off and result in breakage of other parts.
4) Check oil level and add to full level.	

## 13-2 PERIODIC MAINTENANCE SCHEDULE

Periodic maintenance is vital to safe and efficient operation of engine.

Check the table below for periodic maintenance intervals.

It is also necessary to conduct the maintenance and adjustments on the emission-related parts listed below to keep the emission control system effective;

- (1) Carburetor and internal parts
- (2) Choke system
- (3) Fuel strainer
- (4) Air cleaner elements
- (5) Intake pipe
- (6) Spark plug
- (7) Magneto
- (8) Fuel hoses, clamps and sealing gaskets

The following maintenance schedule is based on the normal engine operation.

Should the engine be operated in extremely dusty condition or in heavier loading condition, the maintenance interval must be shortened depending on the contamination of oil, clogging of filter elements, wear of parts, and so on.

## Periodic Maintenance Schedule table

Maintenance Items	Every 8 hours (Daily)	Every 20 hours	Every 50 hours	Every 200 hours	Every 500 hours	Every 1000 hours
Clean engine and check bolts and nuts	● (Daily)					
Check and refill engine oil	● (Refill daily to upper level)					
Change engine oil (*Note 1)		● (Initial)	●			
Replace engine oil filter (*Note 1)		● (Initial)		●		
Check battery electrolyte fluid level			●			
Clean spark plug			●			
Clean air cleaner			●			
Replace air cleaner element				●		
Clean fuel strainer				●		
Clean and adjust spark plug and electrodes				●		
Replace spark plug					●	
Remove carbon from cylinder head					●	
Clean and adjust carburetor					●	
Clean engine base (oil pan)					●	
Check and adjust valve clearance					●	
Replace fuel lines						● (Yearly)
Overhaul engine (*Note 2)						●

\*Note 1 : Initial oil change and oil filter replacement should be performed after 20 hours of operation.

Thereafter change oil every 50 hours and replace oil filter 200 hours.

Before changing oil, check for a suitable way to dispose of old oil. Do not pour it down into sewage drains, onto garden soil or into open streams. Your local zoning or environmental regulations will give you more detailed instructions on proper disposal.

\*Note 2 : As to the procedures, please refer to the Service Manual or consult your nearest ROBIN service dealer.

\*Note 3 : More frequent oil changing, oil filter replacement and air cleaner service on replacement may be necessary depending on operating conditions.

This would include dusty environment, high ambient temperature, heavy engine loading.

### **13-3 ENGINE STORAGE**

- (1) Change the engine oil and perform the daily maintenance items above mentioned.
- (2) Drain fuel from carburetor float chamber.
- (3) To prevent rust in the cylinder bore, apply oil through the spark plug hole and turn the crankshaft several turns by hand. Reinstall the plug.
- (4) Turn the crankshaft by hand and leave it where the resistance is the heaviest.
- (5) Clean outside of the engine with oiled cloth.
- (6) Put a plastic cover or the like over the engine and store the engine in dry place.